



2000LT  ARIGO Turbo Atomizör 

 **ARIGO**

FIELD & GARDEN
SPRAYER



BASIC RANGE :
MANUAL HEIGHT ADJUSTED
MANUAL BOOM

- BEE CLASSIC BASIC
- BEE ANATOLIA BASIC
- BEE ANATOLIA STYLE BASIC



GENIUS RANGE :
LIFTED WITHOUT SELF LEVELLING
MANUAL BOOM

- BEE CLASSIC GENIUS
- BEE ANATOLIA GENIUS
- BEE ANATOLIA STYLE GENIUS



FOX RANGE :
LIFTED WITH SELF LEVELLING
MANUAL BOOM

- BEE ANATOLIA FOX
- BEE ANATOLIA STYLE FOX
- BEE SPACE FOX
- BEE MAXI FOX



HIDRO RANGE :
LIFTED WITH SELF LEVELLING
HORIZONTAL HYDRAULIC BOOM

- BEE ANATOLIA HIDRO
- BEE ANATOLIA STYLE HIDRO
- BEE SPACE HIDRO
- BEE MAXI HIDRO



HIDRO X RANGE :
LIFTED WITH SELF LEVELLING
X TYPE HYDRAULIC BOOM

- BEE ANATOLIA HIDRO X
- BEE ANATOLIA STYLE HIDRO X
- BEE SPACE HIDRO X
- BEE MAXI HIDRO X

FIELD SPRAYER

TRAILED FIELD SPRAYER



WASP SERIES



FOX RANGE :
LIFTED WITH SELF LEVELLING
MANUAL BOOM

WASP START STYLE FOX



HIDRO RANGE :
LIFTED WITH SELF LEVELLING
HORIZONTAL HYDRAULIC BOOM

WASP START HIDRO



HIDRO X RANGE :
LIFTED WITH SELF LEVELLING
X TYPE HYDRAULIC BOOM

WASP START HIDRO X

HORNET SERIES



FOX RANGE :
LIFTED WITH SELF LEVELLING
MANUAL BOOM

HORNET KOMPAKT FOX



HIDRO RANGE :
LIFTED WITH SELF LEVELLING
HORIZONTAL HYDRAULIC BOOM

HORNET KOMPAKT HIDRO



HIDRO X RANGE :
LIFTED WITH SELF LEVELLING
X TYPE HYDRAULIC BOOM

HORNETKOMPAKT HIDRO X



HIDRO L RANGE :
PARALLELOGRAM HEIGHT ADJUSTMENT
LATERAL FOLDING LIGHT BOOM

HORNET KOMPAKT AGB



HIDRO L RANGE :
PARALLELOGRAM HEIGHT ADJUSTMENT
LATERAL FOLDING ADVANCED BOOM

HORNET MAXI AGL



HIDRO L RANGE :
PARALLELOGRAM HEIGHT ADJUSTMENT
LATERAL FOLDING ADVANCED BOOM

HORNET MAXI PLUS AGL

HORNET MAXI PLUS AGM



AXIAL ROUND FAN RANGE:
V-BELT TRANSMISSION

OSMIA ANATOLIA EKO
OSMIA ANATOLIA STYLE EKO



AXIAL ROUND FAN RANGE:
V-BELT TRANSMISSION

OSMIA ANATOLIA RAPIDO
OSMIA ANATOLIA STYLE RAPIDO



AXIAL ROUND FAN RANGE:
GEARBOX TRANSMISSION

OSMIA ANATOLIA STYLE SPEED

APIS SERIES



AXIAL LINEAR FAN RANGE:
V-BELT TRANSMISSION

APIS ANATOLIA STYLE RAPIDO



AXIAL LINEAR FAN RANGE:
GEARBOX TRANSMISSION

APIS ANATOLIA STYLE SPEED

CANNON AND ANT SERIES



CENTRIFUGAL FAN RANGE:
CANNON HEAD

CANNON ANATOLIA STYLE



CENTRIFUGAL FAN RANGE:
ROBOT HEAD

ANT ANATOLIA STYLE

MANTIS SERIES



AXIAL ROUND FAN RANGE:
FRONT AIR INTAKE

MANTIS START STYLE
MANTIS EUROPA

RAVEN SERIES



AXIAL LINEAR FAN RANGE:
FRONT AIR INTAKE

RAVEN START STYLE



AXIAL LINEAR FAN RANGE:
REVERSE AIR INTAKE

RAVEN TRIO REVERSE

VESPO & VESPA SERIES



CENTRIFUGAL FAN RANGE:
CANNON HEAD

VESPO TRIO



CENTRIFUGAL FAN RANGE:
ROBOT HEAD

VESPA EUROPA



MOUNTED TYPE GARDEN PULVERIZATOR
AVS

-
- AVES CLASSIC
 - AVES ANATOLIA
 - AVES ANATOLIA STYLE



TRAILED TYPE GARDEN PULVERIZATOR
VIREO

-
- VIREO START



BIG BAG LIFTER
LFT SERIES

ARI-S

ARI-M

ARI-L



BIG BAG LIFTER
LFT SERIES

BLY-S

BLY-M

BLY-L



FIELD SPRAYER

A red tractor is partially visible on the left side of the image, parked in a lush green field. The sky above is filled with large, white, fluffy clouds, suggesting a bright but slightly overcast day. The overall scene is a rural agricultural setting.

 **ARIGO**



TANK

- Polyethylene Tank with Hand Wash
- Capacities : 200 LT - 300 LT - 400 LT - 500 LT - 600 LT - 800 LT - 1000 LT

CHASSIS

- Tubular for 200 LT - 300 LT - 400 LT - 500 LT - 600 LT
- Profile Extended for 400 LT - 500 LT - 600 LT - 800 LT - 1000 LT

PUMP

E-30 Pump



PRESSURE	30 BAR
MEMBRANE	3 PISTON
FLOW RATE	30 LT/MIN

B-71 Pump



PRESSURE	40 BAR
MEMBRANE	3 PISTON
FLOW RATE	70 LT/MIN

B-80 Pump



PRESSURE	40 BAR
MEMBRANE	3 PISTON
FLOW RATE	80 LT/MIN

CONTROL UNIT (REGULATOR)

**C-50
Regulator 2 Way**



**C-50
Regulator 3 Way**



**C-50
Regulator 4 Way**



BOOM

• *Horizontal Manual Folding Boom*

MS Series : 6-8-10-12 MT



TRANSPORT WIDTH
6 MT - 220 CM / 8 MT - 220 CM
10 MT - 230 CM / 12 MT - 280 CM

MK Series : 10-12-14 MT



TRANSPORT WIDTH
10 MT - 245 CM / 12 MT - 295 CM
14 MT - 340 CM

NOZZLE

PBN

**1 Way Plastic Nozzle
without Anti-Drip - PBN**



BBN

**1 Way Brass Nozzle
without Anti-Drip**



1JET

**1 Way Plastic Nozzle
with Anti-Drip**



3JET

**3 Way Plastic Nozzle
with Anti-Drip**





TANK

- Polyethylene Tank with Hand Wash
- Capacities : 200 LT - 300 LT - 400 LT - 500 LT - 600 LT - 800 LT - 1000 LT - 1200 LT

CHASSIS

- Profile Extended

PUMP

E-30 Pump



PRESSURE	30 BAR
MEMBRANE	3 PISTON
FLOW RATE	30 LT/MIN

B-80 Pump



PRESSURE	40 BAR
MEMBRANE	3 PISTON
FLOW RATE	80 LT/MIN

A-105 Pump



PRESSURE	50 BAR
MEMBRANE	4 PISTON
FLOW RATE	105 LT/MIN

CONTROL UNIT (REGULATOR)

**VDR-50
Regulator 2 Way**



**VDR-50
Regulator 3 Way**



**VDR-50
Regulator 4 Way**



BOOM

• *Horizontal Manual Folding Boom*

MS Series : 6-8-10-12 MT



TRANSPORT WIDTH
6 MT - 220 CM / 8 MT - 220 CM
10 MT - 230 CM / 12 MT - 280 CM

MK Series : 10-12-14 MT



TRANSPORT WIDTH
10 MT - 245 CM / 12 MT - 295 CM
14 MT - 340 CM

NOZZLE

PBN

1 Way Plastic Nozzle
without Anti-Drip - PBN



BBN

1 Way Brass Nozzle
without Anti-Drip



1JET

1 Way Plastic Nozzle
with Anti-Drip



3JET

3 Way Plastic Nozzle
with Anti-Drip





TANK

- Polyethylene Tank with Hand Wash + Clean Water Tank
- Capacities : 200 LT - 300 LT - 400 LT - 500 LT - 600 LT - 800 LT - 1000 LT - 1200 LT

CHASSIS

- Profile Extended

PUMP

E-30 Pump



PRESSURE	30 BAR
MEMBRANE	3 PISTON
FLOW RATE	30 LT/MIN

B-80 Pump



PRESSURE	40 BAR
MEMBRANE	3 PISTON
FLOW RATE	80 LT/MIN

A-105 Pump



PRESSURE	50 BAR
MEMBRANE	4 PISTON
FLOW RATE	105 LT/MIN

CONTROL UNIT (REGULATOR)

VDR-50 Regulator 2 Way



VDR-50 Regulator 3 Way



VDR-50 Regulator 4 Way



BOOM

• *Horizontal Manual Folding Boom*

MS Series : 6-8-10-12 MT



TRANSPORT WIDTH	6 MT - 220 CM / 8 MT - 220 CM 10 MT - 230 CM / 12 MT - 280 CM
-----------------	--

MK Series : 10-12-14 MT



TRANSPORT WIDTH	10 MT - 245 CM / 12 MT - 295 CM 14 MT - 340 CM
-----------------	---

MX Series : 12-15 MT



TRANSPORT WIDTH	12 MT - 250 CM 15 MT - 295 CM
-----------------	----------------------------------

NOZZLE

PBN
1 Way Plastic Nozzle without Anti-Drip - PBN



BBN
1 Way Brass Nozzle without Anti-Drip



1JET
1 Way Plastic Nozzle with Anti-Drip



3JET
3 Way Plastic Nozzle with Anti-Drip





TANK

- Polyethylene Tank with Hand Wash
- Capacities : 600 LT – 800 LT – 1000 LT

CHASSIS

- Mechanical Height Adjusted
- Hydraulic Height Adjusted

PUMP

B-71 Pump



PRESSURE	40 BAR
MEMBRANE	3 PISTON
FLOW RATE	70 LT/MIN

B-80 Pump



PRESSURE	40 BAR
MEMBRANE	3 PISTON
FLOW RATE	80 LT/MIN

A-105 Pump



PRESSURE	50 BAR
MEMBRANE	4 PISTON
FLOW RATE	105 LT/MIN

CONTROL UNIT (REGULATOR)

C-50
Regulator 2 Way



C-50
Regulator 3 Way



C-50
Regulator 4 Way



VDR-50
Regulator 2 Way



VDR-50
Regulator 3 Way



VDR-50
Regulator 4 Way



BOOM

• Horizontal Manual Folding Boom

MS Series : 12 MT



TRANSPORT WIDTH
12 MT - 280 CM

MK Series : 12-14 MT



TRANSPORT WIDTH
12 MT - 295 CM / 14 MT - 340 CM

NOZZLE

PBN

1 Way Plastic Nozzle
without Anti-Drip - PBN



BBN

1 Way Brass Nozzle
without Anti-Drip



1JET

1 Way Plastic Nozzle
with Anti-Drip



3JET

3 Way Plastic Nozzle
with Anti-Drip





TANK

- *Polyethylene Tank with Hand Wash*
- *Capacities : 600 LT - 800 LT - 1000 LT - 1200 LT*

CHASSIS

- *Mechanical Height Adjusted*
- *Hydraulic Height Adjusted*

PUMP

B-80 Pump



PRESSURE	40 BAR
MEMBRANE	3 PISTON
FLOW RATE	80 LT/MIN

A-105 Pump



PRESSURE	50 BAR
MEMBRANE	4 PISTON
FLOW RATE	105 LT/MIN

CONTROL UNIT (REGULATOR)

VDR-50 Regulator 2 Way



VDR-50 Regulator 3 Way



VDR-50 Regulator 4 Way



BOOM

• *Horizontal Manual Folding Boom*

MS Series : 12 MT



TRANSPORT WIDTH
12 MT - 280 CM

MK Series : 12-14 MT



TRANSPORT WIDTH
12 MT - 295 CM / 14 MT - 340 CM

NOZZLE

PBN
1 Way Plastic Nozzle without Anti-Drip - PBN



BBN
1 Way Brass Nozzle without Anti-Drip



1JET
1 Way Plastic Nozzle with Anti-Drip



3JET
3 Way Plastic Nozzle with Anti-Drip





TANK

- Polyethylene Tank with Hand Wash + Clean Water Tank
- Capacities : 600 LT – 800 LT – 1000 LT – 1200 LT

CHASSIS

- Mechanical Height Adjusted
- Hydraulic Height Adjusted

PUMP

B-80 Pump



PRESSURE	40 BAR
MEMBRANE	3 PISTON
FLOW RATE	80 LT/MIN

A-105 Pump



PRESSURE	50 BAR
MEMBRANE	4 PISTON
FLOW RATE	105 LT/MIN

CONTROL UNIT (REGULATOR)

**VDR-50
Regulator 2 Way**



**VDR-50
Regulator 3 Way**



**VDR-50
Regulator 4 Way**



BOOM

• *Horizontal Manual Folding Boom*

MS Series : 12 MT



**TRANSPORT WIDTH
12 MT - 280 CM**

MK Series : 12-14 MT



**TRANSPORT WIDTH
12 MT - 295 CM / 14 MT - 340 CM**

NOZZLE

PBN
1 Way Plastic Nozzle
without Anti-Drip - PBN



BBN
1 Way Brass Nozzle
without Anti-Drip



1JET
1 Way Plastic Nozzle
with Anti-Drip



3JET
3 Way Plastic Nozzle
with Anti-Drip





TANK

- Polyethylene Tank with Hand Wash
- Capacities : 600 LT – 800 LT – 1000 LT – 1200 LT

CHASSIS

- Hydraulic Height Adjusted
- Self Levelling Device

PUMP

A-105 Pump



PRESSURE	50 BAR
MEMBRANE	4 PISTON
FLOW RATE	105 LT/MIN

IDM-140 Pump



PRESSURE	50 BAR
MEMBRANE	3 PISTON
FLOW RATE	137 LT/MIN

CONTROL UNIT (REGULATOR)VDR-50
Regulator 5 Way**BOOM**• *Horizontal Manual Folding Boom*

BS Series : 12-14-15-16-18 MT

TRANSPORT WIDTH
12 MT - 14 MT - 15 MT - 16 MT - 280 CM
18 MT - 400 CM**NOZZLE**

PBN

1 Way Plastic Nozzle
without Anti-Drip - PBN

BBN

1 Way Brass Nozzle
without Anti-Drip

1JET

1 Way Plastic Nozzle
with Anti-Drip

3JET

3 Way Plastic Nozzle
with Anti-Drip**OPTIONAL**Arigo
Premixer



TANK

- Polyethylene Tank with Hand Wash + Clean Water Tank
- Capacities : 600 LT – 800 LT – 1000 LT – 1200 LT

CHASSIS

- Hydraulic Height Adjusted
- Self Levelling Device

PUMP

A-105 Pump



PRESSURE	50 BAR
MEMBRANE	4 PISTON
FLOW RATE	105 LT/MIN

IDM-140 Pump



PRESSURE	50 BAR
MEMBRANE	3 PISTON
FLOW RATE	137 LT/MIN

POLY2105 Pump



PRESSURE	15 BAR
MEMBRANE	3 PISTON
FLOW RATE	105 LT/MIN

POLY2150 Pump



PRESSURE	15 BAR
MEMBRANE	3 PISTON
FLOW RATE	150 LT/MIN

CONTROL UNIT (REGULATOR)

**NDR
Regulator**



**Bertolini
RS Regulator**



**Arag 471
Proportional Valve**



**Geoline
Baby Driver 06**



**Geoline
Midi Driver 06**



**Geoline
Kit Driver 06**



**Arag Bravo 180S
Computer Control**



BOOM

BS Series : 12-14-15-16-18 MT



TRANSPORT WIDTH
12 MT - 14 MT - 15 MT - 16 MT - 280 CM
18 MT - 400 CM

• Horizontal Manual Folding Boom

NOZZLE

PBN

**1 Way Plastic Nozzle
without Anti-Drip - PBN**



BBN

**1 Way Brass Nozzle
without Anti-Drip**



1JET

**1 Way Plastic Nozzle
with Anti-Drip**



3JET

**3 Way Plastic Nozzle
with Anti-Drip**



OPTIONAL

**Arigo
Premixer**



**Geoline
Premixer**



**Polmac
Premixer**





TANK

- Polyethylene Tank with Hand Wash + Clean Water Tank
- Capacities : 900 LT – 1100 LT – 1300 LT

CHASSIS

- Hydraulic Height Adjusted
- Self Levelling Device

PUMP

A-105 Pump



PRESSURE	50 BAR
MEMBRANE	4 PISTON
FLOW RATE	105 LT/MIN

IDM-140 Pump



PRESSURE	50 BAR
MEMBRANE	3 PISTON
FLOW RATE	137 LT/MIN

IDM-200 Pump



PRESSURE	50 BAR
MEMBRANE	4 PISTON
FLOW RATE	180 LT/MIN

POLY2105 Pump



PRESSURE	15 BAR
MEMBRANE	3 PISTON
FLOW RATE	105 LT/MIN

POLY2150 Pump



PRESSURE	15 BAR
MEMBRANE	3 PISTON
FLOW RATE	150 LT/MIN

CONTROL UNIT (REGULATOR)

**NDR
Regulator**



**Bertolini
RS Regulator**



**Arag 471
Proportional Valve**



**Geoline
Baby Driver 06**



**Geoline
Midi Driver 06**



**Geoline
Kit Driver 06**



**Arag Bravo 180S
Computer Control**



BOOM

• *Horizontal Manual Folding Boom*

BS Series : 12-14-15-16-18 MT



TRANSPORT WIDTH
12 MT - 14 MT - 15 MT - 16 MT - 280 CM
18 MT - 400 CM

NOZZLE

PBN
1 Way Plastic Nozzle
without Anti-Drip - PBN



BBN
1 Way Brass Nozzle
without Anti-Drip



1JET
1 Way Plastic Nozzle
with Anti-Drip



3JET
3 Way Plastic Nozzle
with Anti-Drip



OPTIONAL

**Space
Premixer**





TANK

- Polyethylene Tank with Hand Wash + Clean Water Tank
- Capacities : 1600 LT – 1800 LT

CHASSIS

- Hydraulic Height Adjusted
- Self Levelling Device

PUMP

A-105 Pump



PRESSURE	50 BAR
MEMBRANE	4 PISTON
FLOW RATE	105 LT/MIN

IDM-140 Pump



PRESSURE	50 BAR
MEMBRANE	3 PISTON
FLOW RATE	137 LT/MIN

IDM-200 Pump



PRESSURE	50 BAR
MEMBRANE	4 PISTON
FLOW RATE	180 LT/MIN

POLY2105 Pump



PRESSURE	15 BAR
MEMBRANE	3 PISTON
FLOW RATE	105 LT/MIN

POLY2150 Pump



PRESSURE	15 BAR
MEMBRANE	3 PISTON
FLOW RATE	150 LT/MIN

CONTROL UNIT (REGULATOR)

**NDR
Regulator**



**Bertolini
RS Regulator**



**Arag 471
Proportional Valve**



**Geoline
Baby Driver 06**



**Geoline
Midi Driver 06**



**Geoline
Kit Driver 06**



**Arag Bravo 180S
Computer Control**



BOOM

• *Horizontal Manual Folding Boom*

BS Series : 12-14-15-16-18 MT



TRANSPORT WIDTH
12 MT - 14 MT - 15 MT - 16 MT - 280 CM
18 MT - 400 CM

NOZZLE

PBN

**1 Way Plastic Nozzle
without Anti-Drip - PBN**



BBN

**1 Way Brass Nozzle
without Anti-Drip**



1JET

**1 Way Plastic Nozzle
with Anti-Drip**



3JET

**3 Way Plastic Nozzle
with Anti-Drip**



OPTIONAL

**Arigo
Premixer**





TANK

- Polyethylene Tank with Hand Wash
- Capacities : 600 LT – 800 LT – 1000 LT – 1200 LT

CHASSIS

- Hydraulic Height Adjusted
- Self Levelling Device

PUMP

A-105 Pump



PRESSURE	50 BAR
MEMBRANE	4 PISTON
FLOW RATE	105 LT/MIN

IDM-140 Pump



PRESSURE	50 BAR
MEMBRANE	3 PISTON
FLOW RATE	137 LT/MIN

CONTROL UNIT (REGULATOR)

VDR-50
Regulator 5 Way



BOOM

• *Horizontal Hydraulic Folding Boom*

HL Series : 12-15-18 MT



TRANSPORT WIDTH
12 MT - 280 CM / 15 MT - 350 CM
18 MT - 400 CM

BOOM HYDRAULIC CONTROL

Manual Lever



Sequence Opening



Mechanical Lever



NOZZLE

PBN
1 Way Plastic Nozzle
without Anti-Drip - PBN



BBN
1 Way Brass Nozzle
without Anti-Drip



1JET
1 Way Plastic Nozzle
with Anti-Drip



3JET
3 Way Plastic Nozzle
with Anti-Drip



OPTIONAL

Arigo
Premixer





TANK

- Polyethylene Tank with Hand Wash + Clean Water Tank
- Capacities : 600 LT – 800 LT – 1000 LT – 1200 LT

CHASSIS

- Hydraulic Height Adjusted
- Self Levelling Device

PUMP

A-105 Pump



PRESSURE	50 BAR
MEMBRANE	4 PISTON
FLOW RATE	105 LT/MIN

IDM-140 Pump



PRESSURE	50 BAR
MEMBRANE	3 PISTON
FLOW RATE	137 LT/MIN

POLY2105 Pump



PRESSURE	15 BAR
MEMBRANE	3 PISTON
FLOW RATE	105 LT/MIN

POLY2150 Pump



PRESSURE	15 BAR
MEMBRANE	3 PISTON
FLOW RATE	150 LT/MIN

CONTROL UNIT (REGULATOR)

**NDR
Regulator**



**Bertolini
RS Regulator**



**Arag 471
Proportional Valve**



**Geoline
Baby Driver 06**



**Geoline
Midi Driver 06**



**Geoline
Kit Driver 06**



**Arag Bravo 180 S
Computer Control**



BOOM

HL Series : 12-15-18 MT



TRANSPORT WIDTH
12 MT - 280 CM / 15 MT - 350 CM
18 MT - 400 CM

• *Horizontal Hydraulic Folding Boom*

BOOM HYDRAULIC CONTROL

Sequence Opening



Electric Joystick



Manual Lever



Mechanical Lever



NOZZLE

PBN

**1 Way Plastic Nozzle
without Anti-Drip - PBN**



BBN

**1 Way Brass Nozzle
without Anti-Drip**



1JET

**1 Way Plastic Nozzle
with Anti-Drip**



3JET

**3 Way Plastic Nozzle
with Anti-Drip**



OPTIONAL

**Arigo
Premixer**



**Polmac
Premixer**



**Geoline
Premixer**





TANK

- Polyethylene Tank with Hand Wash + Clean Water Tank
- Capacities : 900 LT – 1100 LT – 1300 LT

CHASSIS

- Hydraulic Height Adjusted
- Self Levelling Device

PUMP

A-105 Pump



PRESSURE	50 BAR
MEMBRANE	4 PISTON
FLOW RATE	105 LT/MIN

IDM-140 Pump



PRESSURE	50 BAR
MEMBRANE	3 PISTON
FLOW RATE	137 LT/MIN

IDM-200 Pump



PRESSURE	50 BAR
MEMBRANE	4 PISTON
FLOW RATE	180 LT/MIN

POLY2105 Pump



PRESSURE	15 BAR
MEMBRANE	3 PISTON
FLOW RATE	105 LT/MIN

POLY2150 Pump



PRESSURE	15 BAR
MEMBRANE	3 PISTON
FLOW RATE	150 LT/MIN

CONTROL UNIT (REGULATOR)



BOOM



• Horizontal Hydraulic Folding Boom

BOOM HYDRAULIC CONTROL

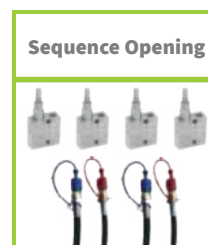

NOZZLE



OPTIONAL





TANK

- Polyethylene Tank with Hand Wash + Clean Water Tank
- Capacities : 1600 LT – 1800 LT

CHASSIS

- Hydraulic Height Adjusted
- Self Levelling Device

PUMP

A-105 Pump



PRESSURE	50 BAR
MEMBRANE	4 PISTON
FLOW RATE	105 LT/MIN

IDM-140 Pump



PRESSURE	50 BAR
MEMBRANE	3 PISTON
FLOW RATE	137 LT/MIN

IDM-200 Pump



PRESSURE	50 BAR
MEMBRANE	4 PISTON
FLOW RATE	180 LT/MIN

POLY2105 Pump



PRESSURE	15 BAR
MEMBRANE	3 PISTON
FLOW RATE	105 LT/MIN

POLY2150 Pump



PRESSURE	15 BAR
MEMBRANE	3 PISTON
FLOW RATE	150 LT/MIN

CONTROL UNIT (REGULATOR)

**NDR
Regulator**



**Bertolini
RS Regulator**



**Arag 471
Proportional Valve**



**Geoline
Baby Driver 06**



**Geoline
Midi Driver 06**



**Geoline
Kit Driver 06**



**Arag Bravo 180 S
Computer Control**



BOOM

HL Series : 12-15-18 MT



TRANSPORT WIDTH
12 MT - 280 CM / 15 MT - 350 CM
18 MT - 400 CM

• *Horizontal Hydraulic Folding Boom*

BOOM HYDRAULIC CONTROL

Manual Lever



Mechanical Lever

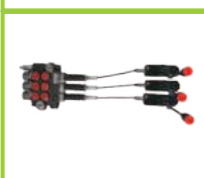

Sequence Opening



Electric Joystick



NOZZLE

PBN

**1 Way Plastic Nozzle
without Anti-Drip - PBN**



BBN

**1 Way Brass Nozzle
without Anti-Drip**



1JET

**1 Way Plastic Nozzle
with Anti-Drip**



3JET

**3 Way Plastic Nozzle
with Anti-Drip**



OPTIONAL

**Arigo
Premixer**



**Polmac
Premixer**



**Geoline
Premixer**





TANK

- Polyethylene Tank with Hand Wash
- Capacities : 600 LT – 800 LT – 1000 LT – 1200 LT

CHASSIS

- Hydraulic Height Adjusted
- Self Levelling Device

PUMP

A-105 Pump



PRESSURE	50 BAR
MEMBRANE	4 PISTON
FLOW RATE	105 LT/MIN

IDM-140 Pump



PRESSURE	50 BAR
MEMBRANE	3 PISTON
FLOW RATE	137 LT/MIN

CONTROL UNIT (REGULATOR)

VDR-50
Regulator 5 Way



BOOM

• X Type Hydraulic Folding Boom

XL Series : 12-15-16 MT



TRANSPORT WIDTH
12 MT - 250 CM / 15 MT - 275 CM
16 MT - 300 CM

XW Series : 12-15-16 MT



TRANSPORT WIDTH
12 MT - 250 CM / 15 MT - 275 CM
16 MT - 300 CM

BOOM HYDRAULIC CONTROL

Direct to Tractor



Manual Lever



NOZZLE

1 Way Plastic Nozzle
without Anti-Drip - PBN



BBN

1 Way Brass Nozzle
without Anti-Drip



1JET

1 Way Plastic Nozzle
with Anti-Drip



3JET

3 Way Plastic Nozzle
with Anti-Drip



OPTIONAL

Arigo
Premixer



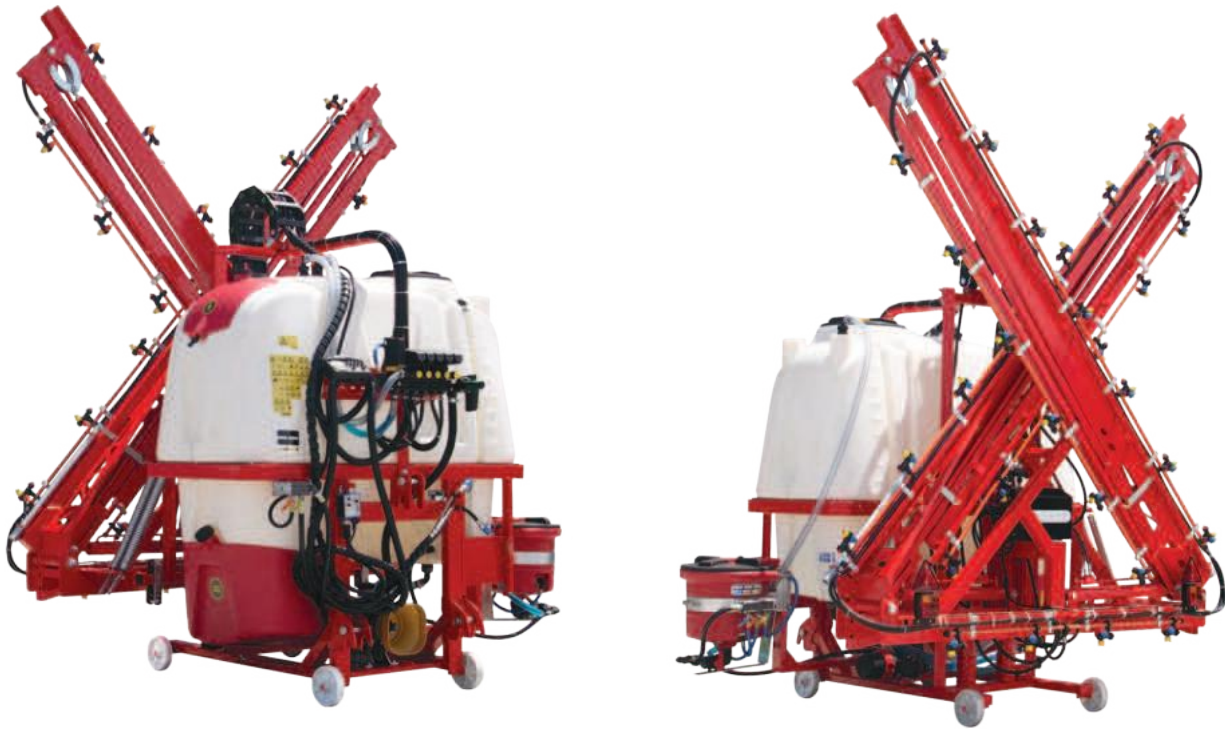





TANK

- Polyethylene Tank with Hand Wash + Clean Water Tank
- Capacities : 600 LT – 800 LT – 1000 LT – 1200 LT

CHASSIS

- Hydraulic Height Adjusted
- Self Levelling Device for XL and XW
- Self Levelling Device with Manual Tilting for XB
- Self Levelling Device with Hydraulic Tilting for XB

PUMP

A-105 Pump		IDM-140 Pump		POLY2105 Pump		POLY2150 Pump	
							
PRESSURE	50 BAR	PRESSURE	50 BAR	PRESSURE	15 BAR	PRESSURE	15 BAR
MEMBRANE	4 PISTON	MEMBRANE	3 PISTON	MEMBRANE	3 PISTON	MEMBRANE	3 PISTON
FLOW RATE	105 LT/MIN	FLOW RATE	137 LT/MIN	FLOW RATE	105 LT/MIN	FLOW RATE	150 LT/MIN

CONTROL UNIT (REGULATOR)



BOOM

• X Type Hydraulic Folding Boom

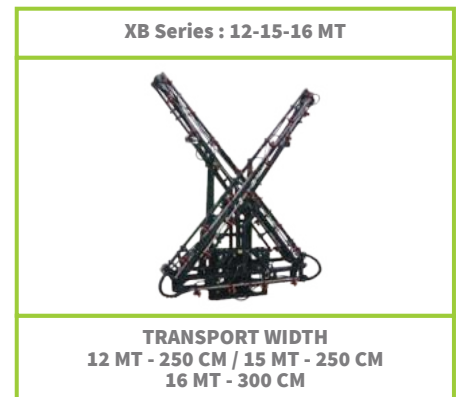

BOOM HYDRAULIC CONTROL



OPTIONAL



NOZZLE





TANK

- Polyethylene Tank with Hand Wash + Clean Water Tank
- Capacities : 900 LT – 1100 LT – 1300 LT

CHASSIS

- Hydraulic Height Adjusted
- Self Levelling Device for XL and XW
- Self Levelling Device with Manual Tilting for XB
- Self Levelling Device with Hydraulic Tilting for XB

OPTIONAL

Space
Premixer



PUMP

A-105 Pump



PRESSURE	50 BAR
MEMBRANE	4 PISTON
FLOW RATE	105 LT/MIN

IDM-140 Pump



PRESSURE	50 BAR
MEMBRANE	3 PISTON
FLOW RATE	137 LT/MIN

IDM-200 Pump



PRESSURE	50 BAR
MEMBRANE	4 PISTON
FLOW RATE	180 LT/MIN

POLY2105 Pump



PRESSURE	15 BAR
MEMBRANE	3 PISTON
FLOW RATE	105 LT/MIN

POLY2150 Pump



PRESSURE	15 BAR
MEMBRANE	3 PISTON
FLOW RATE	150 LT/MIN

CONTROL UNIT (REGULATOR)

NDR
Regulator



Bertolini
RS Regulator



Arag 471
Proportional Valve



Geoline
Baby Driver 06



Geoline
Midi Driver 06



Geoline
Kit Driver 06



Arag Bravo 180 S
Computer Control



BOOM

• X Type Hydraulic Folding Boom

XL Series : 12-15-16 MT



TRANSPORT WIDTH
12 MT - 250 CM / 15 MT - 275 CM
16 MT - 300 CM

XW Series : 12-15-16 MT



TRANSPORT WIDTH
12 MT - 250 CM / 15 MT - 275 CM
16 MT - 300 CM

XB Series : 12-15-16 MT



TRANSPORT WIDTH
12 MT - 250 CM / 15 MT - 250 CM
16 MT - 300 CM

BOOM HYDRAULIC CONTROL

Direct to Tractor



Manual Lever



Mechanical Lever



Electric Joystick



NOZZLE

PBN

1 Way Plastic Nozzle
without Anti-Drip - PBN



BBN

1 Way Brass Nozzle
without Anti-Drip



1JET

1 Way Plastic Nozzle
with Anti-Drip



3JET

3 Way Plastic Nozzle
with Anti-Drip





TANK

- Polyethylene Tank with Hand Wash + Clean Water Tank
- Capacities : 1600 LT – 1800 LT

CHASSIS

- Hydraulic Height Adjusted
- Self Levelling Device for XL and XW
- Self Levelling Device with Manual Tilting for XB
- Self Levelling Device with Hydraulic Tilting for XB

PUMP

A-105 Pump



PRESSURE	50 BAR
MEMBRANE	4 PISTON
FLOW RATE	105 LT/MIN

IDM-140 Pump



PRESSURE	50 BAR
MEMBRANE	3 PISTON
FLOW RATE	137 LT/MIN

IDM-200 Pump



PRESSURE	50 BAR
MEMBRANE	4 PISTON
FLOW RATE	180 LT/MIN

POLY2105 Pump



PRESSURE	15 BAR
MEMBRANE	3 PISTON
FLOW RATE	105 LT/MIN

POLY2150 Pump



PRESSURE	15 BAR
MEMBRANE	3 PISTON
FLOW RATE	150 LT/MIN

CONTROL UNIT (REGULATOR)



BOOM

• X Type Hydraulic Folding Boom



BOOM HYDRAULIC CONTROL

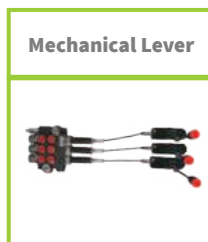
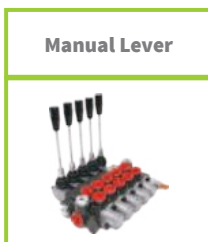
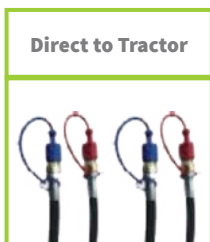

OPTIONAL



NOZZLE





TANK

- Polyethylene Tank with Hand Wash + Clean Water Tank
- Capacities : 1000 LT - 1600 LT - 2000 LT - 3000 LT

CHASSIS

- Hydraulic Height Adjusted
- Self Levelling Device

TIRE

- 10.0/80-12 for 1000 LT - 10.0/75-15.3 for 1600 LT and 2000 LT
- 11.5/80-15.3 for 3000 LT

DRAWBAR



PUMP

A-105 Pump



PRESSURE	50 BAR
MEMBRANE	4 PISTON
FLOW RATE	105 LT/MIN

IDM-140 Pump



PRESSURE	50 BAR
MEMBRANE	3 PISTON
FLOW RATE	137 LT/MIN

IDM-200 Pump



PRESSURE	50 BAR
MEMBRANE	4 PISTON
FLOW RATE	180 LT/MIN

CONTROL UNIT (REGULATOR)

**VDR-50
Regulator 5 Way**



BOOM

• *Horizontal Manual Folding Boom*

BS Series : 12-14-15-16-18 MT



TRANSPORT WIDTH
12 MT - 14 MT - 15 MT - 16 MT - 280 CM
18 MT - 400 CM

NOZZLE

PBN

**1 Way Plastic Nozzle
without Anti-Drip - PBN**



BBN

**1 Way Brass Nozzle
without Anti-Drip**



1JET

**1 Way Plastic Nozzle
with Anti-Drip**



3JET

**3 Way Plastic Nozzle
with Anti-Drip**



OPTIONAL

**Arigo
Premixer**





TANK

- Polyethylene Tank with Hand Wash
- Capacities : 1000 LT - 1600 LT - 2000 LT - 3000 LT

CHASSIS

- Hydraulic Height Adjusted
- Self Levelling Device

TIRE

- 10.0/80-12 for 1000 LT - 10.0/75-15.3 for 1600 LT and 2000 LT
- 11.5/80-15.3 for 3000 LT

DRAWBAR



OPTIONAL



PUMP

A-105 Pump



PRESSURE	50 BAR
MEMBRANE	4 PISTON
FLOW RATE	105 LT/MIN

IDM-140 Pump



PRESSURE	50 BAR
MEMBRANE	3 PISTON
FLOW RATE	137 LT/MIN

IDM-200 Pump



PRESSURE	50 BAR
MEMBRANE	4 PISTON
FLOW RATE	180 LT/MIN

CONTROL UNIT (REGULATOR)

**VDR-50
Regulator 5 Way**



BOOM

• *Horizontal Hydraulic
Folding Boom*

HL Series : 12-15-18 MT



TRANSPORT WIDTH
12 MT - 280 CM / 15 MT - 350 CM
18 MT - 400 CM

BOOM HYDRAULIC CONTROL

Manual Lever



Sequence Opening



NOZZLE

PBN

**1 Way Plastic Nozzle
without Anti-Drip - PBN**



BBN

**1 Way Brass Nozzle
without Anti-Drip**



1JET

**1 Way Plastic Nozzle
with Anti-Drip**



3JET

**3 Way Plastic Nozzle
with Anti-Drip**





TANK

- Polyethylene Tank with Hand Wash
- Capacities : 1000 LT – 1600 LT -2000 LT – 3000 LT

CHASSIS

- Hydraulic Height Adjusted
- Self Levelling Device

TIRE

- 10.0/80-12 for 1000 LT - 10.0/75-15.3 for 1600 LT and 2000 LT
- 11.5/80-15.3 for 3000 LT

DRAWBAR



OPTIONAL



PUMP

CONTROL UNIT (REGULATOR)

A-105 Pump



PRESSURE	50 BAR
MEMBRANE	4 PISTON
FLOW RATE	105 LT/MIN

IDM-140 Pump



PRESSURE	50 BAR
MEMBRANE	3 PISTON
FLOW RATE	137 LT/MIN

IDM-200 Pump



PRESSURE	50 BAR
MEMBRANE	4 PISTON
FLOW RATE	180 LT/MIN

VDR-50 Regulator 5 Way



BOOM

• X Type Hydraulic Folding Boom

XL Series : 12-15-16 MT



TRANSPORT WIDTH
12 MT - 250 CM / 15 MT - 275 CM
16 MT - 300 CM

XW Series : 12-15-16 MT



TRANSPORT WIDTH
12 MT - 250 CM / 15 MT - 275 CM
16 MT - 300 CM

NOZZLE

BOOM HYDRAULIC CONTROL

PBN
1 Way Plastic Nozzle without Anti-Drip - PBN



BBN
1 Way Brass Nozzle without Anti-Drip



1JET
1 Way Plastic Nozzle with Anti-Drip



3JET
3 Way Plastic Nozzle with Anti-Drip



Direct to Tractor



Manual Lever





TANK

- *Polyethylene Tank with Hand Wash + Clean Water Tank*
- *Capacities : 2000 LT – 2500 LT – 3000 LT*

CHASSIS

- *Hydraulic Height Adjusted*
- *Self Levelling Device*

DRAWBAR

FDW
Straight Drawbar

FSW
Steering Drawbar

C1W
Pump Steering at 1 Axis Drawbar

C2W
Pump Steering at 2 Axis Drawbar

TIRE

• 230/95R32 -270/95R32

PUMP

A-105 Pump	
PRESSURE	50 BAR
MEMBRANE	4 PISTON
FLOW RATE	105 LT/MIN

IDM-140 Pump	
PRESSURE	50 BAR
MEMBRANE	3 PISTON
FLOW RATE	137 LT/MIN

IDM-200 Pump	
PRESSURE	50 BAR
MEMBRANE	4 PISTON
FLOW RATE	180 LT/MIN

POLY2150 Pump	
PRESSURE	15 BAR
MEMBRANE	3 PISTON
FLOW RATE	150 LT/MIN

POLY2180 Pump	
PRESSURE	15 BAR
MEMBRANE	3 PISTON
FLOW RATE	170 LT/MIN

CONTROL UNIT (REGULATOR)

NDR Regulator

Bertolini RS Regulator

Arag 471 Proportional Valve

Geoline Baby Driver 06

Geoline Midi Driver 06

Geoline Kit Driver 06

Arag Bravo 180 S Computer Control

BOOM

BS Series : 12-14-15-16-18 MT



TRANSPORT WIDTH
12 MT - 14 MT - 15 MT - 16 MT - 280 CM
18 MT - 400 CM

NOZZLE

PBN

1 Way Plastic Nozzle
without Anti-Drip - PBN



BBN

1 Way Brass Nozzle
without Anti-Drip



1JET

1 Way Plastic Nozzle
with Anti-Drip



3JET

3 Way Plastic Nozzle
with Anti-Drip



OPTIONAL

Arigo
Premixer



Geoline
Premixer



Polmac
Premixer



HDL

HORNET
KOMPAKT FOX





TANK

- *Polyethylene Tank with Hand Wash + Clean Water Tank*
- *Capacities : 2000 LT – 2500 LT – 3000 LT*

CHASSIS

- *Hydraulic Height Adjusted*
- *Self Levelling Device*

DRAWBAR

FDW
Straight Drawbar

FSW
Steering Drawbar

C1W
Pump Steering at 1 Axis Drawbar

C2W
Pump Steering at 2 Axis Drawbar

TIRE

• 210/95R32 - 230/95R32

PUMP

A-105 Pump	
	
PRESSURE	50 BAR
MEMBRANE	4 PISTON
FLOW RATE	105 LT/MIN

IDM-140 Pump	
	
PRESSURE	50 BAR
MEMBRANE	3 PISTON
FLOW RATE	137 LT/MIN

IDM-200 Pump	
	
PRESSURE	50 BAR
MEMBRANE	4 PISTON
FLOW RATE	180 LT/MIN

POLV2150 Pump	
	
PRESSURE	15 BAR
MEMBRANE	3 PISTON
FLOW RATE	150 LT/MIN

CONTROL UNIT (REGULATOR)

NDR Regulator

Bertolini RS Regulator

Arag 471 Proportional Valve

Geoline Baby Driver 06

Geoline Midi Driver 06

Geoline Kit Driver 06

Arag Bravo 180 S Computer Control

BOOM

HL Series : 12-15-18 MT



TRANSPORT WIDTH
12 MT - 280 CM / 15 MT - 350 CM
18 MT - 400 CM

BOOM HYDRAULIC CONTROL

Manual Lever



Mechanical Lever



Sequence Opening



Electric Joystick



NOZZLE

PBN

1 Way Plastic Nozzle
without Anti-Drip - PBN



BBN

1 Way Brass Nozzle
without Anti-Drip



1JET

1 Way Plastic Nozzle
with Anti-Drip



3JET

3 Way Plastic Nozzle
with Anti-Drip



OPTIONAL

Arigo
Premixer



Geoline
Premixer



Polmac
Premixer



HMH

HORNET
KOMPAKT HIDRO





TANK

- *Polyethylene Tank with Hand Wash + Clean Water Tank*
- *Capacities : 2000 LT – 2500 LT – 3000 LT*

CHASSIS

- *Hydraulic Height Adjusted*
- *Self Levelling Device for XL and XW*
- *Self Levelling Device with Manual Tilting for XB*
- *Self Levelling Device with Hydraulic Tilting for XB*

DRAWBAR

FDW
Straight Drawbar

FSW
Steering Drawbar

C1W
Pump Steering at 1 Axis Drawbar

C2W
Pump Steering at 2 Axis Drawbar

TIRE

• 230/95R32 -270/95R32

PUMP

A-105 Pump	
	
PRESSURE	50 BAR
MEMBRANE	4 PISTON
FLOW RATE	105 LT/MIN

IDM-140 Pump	
	
PRESSURE	50 BAR
MEMBRANE	3 PISTON
FLOW RATE	137 LT/MIN

IDM-200 Pump	
	
PRESSURE	50 BAR
MEMBRANE	4 PISTON
FLOW RATE	180 LT/MIN

POLY2150 Pump	
	
PRESSURE	15 BAR
MEMBRANE	3 PISTON
FLOW RATE	150 LT/MIN

POLY2180 Pump	
	
PRESSURE	15 BAR
MEMBRANE	3 PISTON
FLOW RATE	170 LT/MIN

CONTROL UNIT (REGULATOR)

NDR Regulator

Bertolini RS Regulator

Arag 471 Proportional Valve

Geoline Baby Driver 06

Geoline Midi Driver 06

Geoline Kit Driver 06

Arag Bravo 180 S Computer Control

BOOM

• X Type Hydraulic Folding Boom

XL Series : 12-15-16 MT



TRANSPORT WIDTH
12 MT - 250 CM / 15 MT - 275 CM
16 MT - 300 CM

XW Series : 12-15-16 MT



TRANSPORT WIDTH
12 MT - 250 CM / 15 MT - 275 CM
16 MT - 300 CM

XB Series : 12-15-16 MT



TRANSPORT WIDTH
12 MT - 250 CM / 15 MT - 250 CM
16 MT - 300 CM

BOOM HYDRAULIC CONTROL

Direct to Tractor

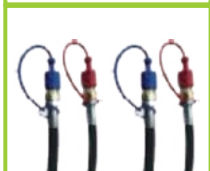

Manual Lever



Mechanical Lever



Electric Joystick



NOZZLE

PBN
1 Way Plastic Nozzle without Anti-Drip - PBN

BBN
1 Way Brass Nozzle without Anti-Drip

1JET
1 Way Plastic Nozzle with Anti-Drip

3JET
3 Way Plastic Nozzle with Anti-Drip

OPTIONAL

Arigo Premixer

Geoline Premixer

Polmac Premixer





TANK

- *Polyethylene Tank with Hand Wash + Clean Water Tank*
- *Capacities : 2000 LT – 2500 LT – 3000 LT*

CHASSIS

- *Parallelogram Hydraulic Height Adjusted*
- *Self Levelling Device with Hydraulic Tilting*

DRAWBAR

FDW
Straight Drawbar

FSW
Steering Drawbar

C1W
Pump Steering at 1 Axis Drawbar

C2W
Pump Steering at 2 Axis Drawbar

TIRE

• 270/95R32 – 230/95R44 – 270/95R44

PUMP

A-105 Pump	
	
PRESSURE	50 BAR
MEMBRANE	4 PISTON
FLOW RATE	105 LT/MIN

IDM-140 Pump	
	
PRESSURE	50 BAR
MEMBRANE	3 PISTON
FLOW RATE	137 LT/MIN

IDM-200 Pump	
	
PRESSURE	50 BAR
MEMBRANE	4 PISTON
FLOW RATE	180 LT/MIN

POLY2150 Pump	
	
PRESSURE	15 BAR
MEMBRANE	3 PISTON
FLOW RATE	150 LT/MIN

POLY2180 Pump	
	
PRESSURE	15 BAR
MEMBRANE	3 PISTON
FLOW RATE	170 LT/MIN

CONTROL UNIT (REGULATOR)

NDR Regulator

Bertolini RS Regulator

Arag 471 Proportional Valve

Geoline Baby Driver 06

Geoline Midi Driver 06

Geoline Kit Driver 06

Arag Bravo 180 S Computer Control

BOOM

• *Lateral Type Hydraulic Folding Boom*

AGB Series : 18-20-21-22-24 MT



TRANSPORT WIDTH
18 MT - 245 CM / 20 MT - 245 CM / 21 MT - 245 CM
22 MT - 245 CM / 24 MT - 245 CM

BOOM HYDRAULIC CONTROL

Manual Lever



Mechanical Lever



Electric Joystick



NOZZLE

1JET

1 Way Plastic Nozzle
with Anti-Drip



3JET

3 Way Plastic Nozzle
with Anti-Drip



OPTIONAL

Arigo
Premixer



Geoline
Premixer



Polmac
Premixer





TANK

- *Polyethylene Tank with Hand Wash + Clean Water Tank*
- *Capacities : 2000 LT – 2500 LT – 3000 LT*

CHASSIS

- *Parallelogram Hydraulic Height Adjusted*
- *Self Levelling Device with Hydraulic Tilting*
- *Variable Geometry*
- *Horizontal Shock Absorber*

DRAWBAR

FDW
Straight Drawbar

FSW
Steering Drawbar

C1W
Pump Steering at 1 Axis Drawbar

TIRE

• 270/95R44 - 270/95R48

PUMP

POLY2150 Pump	
	
PRESSURE	15 BAR
MEMBRANE	3 PISTON
FLOW RATE	150 LT/MIN

POLY2180 Pump	
	
PRESSURE	15 BAR
MEMBRANE	3 PISTON
FLOW RATE	170 LT/MIN

POLY2240 Pump	
	
PRESSURE	15 BAR
MEMBRANE	3 PISTON
FLOW RATE	240 LT/MIN

CONTROL UNIT (REGULATOR)

Arag Bravo 180 S Computer Control	
	

Arag Bravo 400S-LT Computer Control	
	

BOOM

• *Lateral Type Hydraulic Folding Boom*

AGL Series : 20-21-22-24 MT



TRANSPORT WIDTH
20 MT - 255 CM / 21 MT - 255 CM
22 MT - 255 CM / 24 MT - 255 CM

BOOM HYDRAULIC CONTROL

Electric Joystick



NOZZLE

1JET

1 Way Plastic Nozzle with Anti-Drip



3JET

3 Way Plastic Nozzle with Anti-Drip



OPTIONAL

Arigo Premixer



Geoline Premixer



Polmac Premixer



AGL

HORNET
MAXI AGL





TANK

- *Polyethylene Tank with Hand Wash + Clean Water Tank*
- *Capacities : 3000 LT – 4000 LT – 6000 LT*

CHASSIS

- *Parallelogram Hydraulic Height Adjusted*
- *Self Levelling Device with Hydraulic Tilting*
- *Variable Geometry*
- *Horizontal Shock Absorber*
- *Control Hub*

DRAWBAR

PSW
Straight Drawbar

PCW
Steering Drawbar

TIRE

• 270/95R44 - 270/95R48 - 320/90R52

PUMP

POLY2150 Pump	
	
PRESSURE	15 BAR
MEMBRANE	3 PISTON
FLOW RATE	150 LT/MIN

POLY2180 Pump	
	
PRESSURE	15 BAR
MEMBRANE	3 PISTON
FLOW RATE	170 LT/MIN

POLY2240 Pump	
	
PRESSURE	15 BAR
MEMBRANE	3 PISTON
FLOW RATE	240 LT/MIN

POLY2300 Pump	
	
PRESSURE	15 BAR
MEMBRANE	6 PISTON
FLOW RATE	300 LT/MIN

CONTROL UNIT (REGULATOR)

Arag Bravo 180 S Computer Control	
	

Arag Bravo 400S-LT Computer Control	
	

BOOM

• *Lateral Type Hydraulic Folding Boom*

AGL Series : 20-21-22-24 MT



TRANSPORT WIDTH
20 MT - 255 CM / 21 MT - 255 CM
22 MT - 255 CM / 24 MT - 255 CM

BOOM HYDRAULIC CONTROL

Electric Joystick



NOZZLE

3JET

3 Way Plastic Nozzle
with Anti-Drip



OPTIONAL

Arigo
Premixer



Geoline
Premixer



Polmac
Premixer



AGL

HORNET
MAXI PLUS AGL

ARIGO





TANK

- *Polyethylene Tank with Hand Wash + Clean Water Tank*
- *Capacities : 3000 LT – 4000 LT – 6000 LT*

CHASSIS

- *Parallelogram Hydraulic Height Adjusted*
- *Self Levelling Device with Hydraulic Tilting*
- *Variable Geometry*
- *Horizontal Shock Absorber*
- *Control Hub*

DRAWBAR

PSW
Straight Drawbar

PCW
Steering Drawbar

TIRE

• 270/95R44 - 270/95R48 - 320/90R52

PUMP

POLY2150 Pump	
	
PRESSURE	15 BAR
MEMBRANE	3 PISTON
FLOW RATE	150 LT/MIN

POLY2180 Pump	
	
PRESSURE	15 BAR
MEMBRANE	3 PISTON
FLOW RATE	170 LT/MIN

POLY2240 Pump	
	
PRESSURE	15 BAR
MEMBRANE	3 PISTON
FLOW RATE	240 LT/MIN

POLY2300 Pump	
	
PRESSURE	15 BAR
MEMBRANE	6 PISTON
FLOW RATE	300 LT/MIN

CONTROL UNIT (REGULATOR)

Arag Bravo 180 S Computer Control	
	

Arag Bravo 400S-LT Computer Control	
	

BOOM

• *Lateral Type Hydraulic Folding Boom*

AGM Series : 24-28-30 MT



TRANSPORT WIDTH
24 MT - 255 CM / 28 MT - 255 CM
30 MT - 255 CM

BOOM HYDRAULIC CONTROL

Electric Joystick



NOZZLE

3JET

3 Way Plastic Nozzle
with Anti-Drip



OPTIONAL

Arigo
Premixer



Geoline
Premixer



Polmac
Premixer



AGM

HORNET
MAXI PLUS AGM





2000L



ARIGO Turbo Atomizör



TURBO ATOMIZER





TANK

- Polyethylene Tank with Hand Wash
- Capacities : 200 LT – 300 LT – 400 LT – 500 LT – 600 LT – 800 LT – 1000 LT

PUMP

B-71 Pump



PRESSURE	40 BAR
MEMBRANE	3 PISTON
FLOW RATE	70 LT/MIN

B-80 Pump



PRESSURE	40 BAR
MEMBRANE	3 PISTON
FLOW RATE	80 LT/MIN

CONTROL UNIT (REGULATOR)

**C-50
Regulator 2 Way**



FAN GROUP

HBK Type

- 60 cm (24" – 8 nozzles)
- 75 cm (28" – 10 nozzles)
- Painted
- Hot Galvanized Coated

- Single Propeller
- V-Belt without Neutral Speed

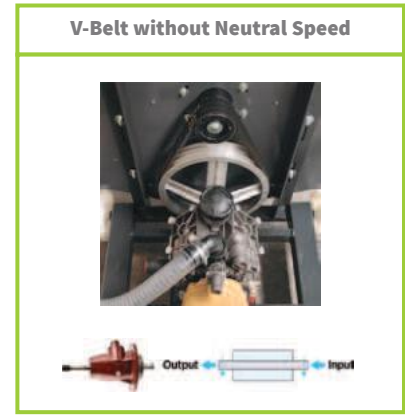
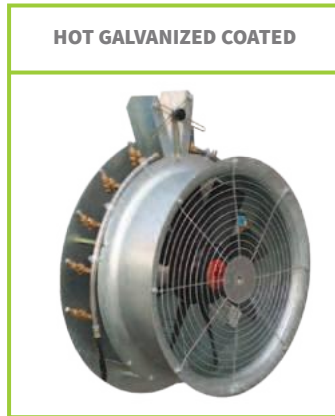

HBA Type

- 60 cm (24" – 8 nozzles)
- 75 cm (28" – 10 nozzles)
- Painted
- Hot Galvanized Coated

- Single Propeller
- V-Belt with Neutral Speed

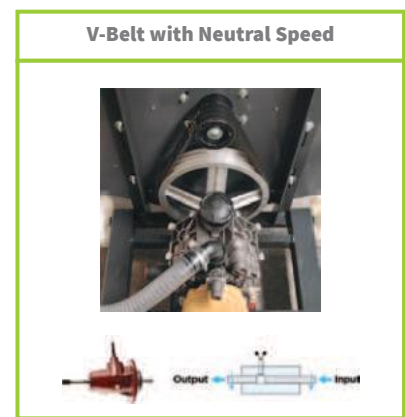

NOZZLE

PLD	PLS	BRD	PRD	PRS
Double Adjustable Plastic Turbo Nozzle without Anti-Drip	Double Adjustable Plastic Turbo Nozzle with Anti-Drip	Double Brass Turbo Nozzle without Anti-Drip	Double Adjustable Brass Turbo Nozzle without Anti-Drip	Double Adjustable Brass Turbo Nozzle with Anti-Drip



TANK

- Polyethylene Tank with Hand Wash
- Capacities : 200 LT – 300 LT – 400 LT – 500 LT – 600 LT – 800 LT – 1000 LT

PUMP

B-80 Pump



PRESSURE	40 BAR
MEMBRANE	3 PISTON
FLOW RATE	80 LT/MIN

CONTROL UNIT (REGULATOR)

VDR-50
Regulator 2 Way



FAN GROUP

HBK Type

- 60 cm (24" – 8 nozzles)
- 75 cm (28" – 10 nozzles)
- Painted
- Hot Galvanized Coated

- Single Propeller
- V-Belt without Neutral Speed

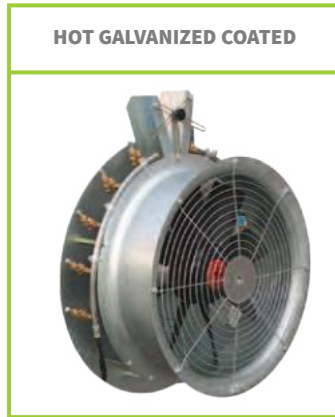

HBA Type

- 60 cm (24" – 8 nozzles)
- 75 cm (28" – 10 nozzles)
- Painted
- Hot Galvanized Coated

- Single Propeller
- V-Belt with Neutral Speed

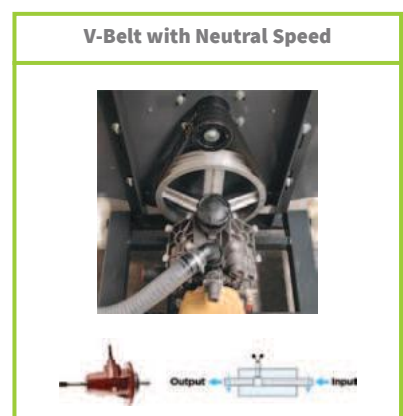

NOZZLE

PLD	PLS	BRD	PRD	PRS
Double Adjustable Plastic Turbo Nozzle without Anti-Drip	Double Adjustable Plastic Turbo Nozzle with Anti-Drip	Double Brass Turbo Nozzle without Anti-Drip	Double Adjustable Brass Turbo Nozzle without Anti-Drip	Double Adjustable Brass Turbo Nozzle with Anti-Drip



TANK

- Polyethylene Tank with Hand Wash + Clean Water Tank
- Capacities : 200 LT - 300 LT - 400 LT - 500 LT - 600 LT - 800 LT - 1000 LT

PUMP

B-80 Pump



PRESSURE	40 BAR
MEMBRANE	3 PISTON
FLOW RATE	80 LT/MIN

CONTROL UNIT (REGULATOR)

**VDR-50
Regulator 2 Way**



**Braglia M200
Pressure Manual**



**Braglia E200
Pressure Electric**



FAN GROUP

HBK Type

- 60 cm (24" – 8 nozzles)
- 75 cm (28" – 10 nozzles)
- Painted
- Hot Galvanized Coated

- Single Propeller
- V-Belt without Neutral Speed

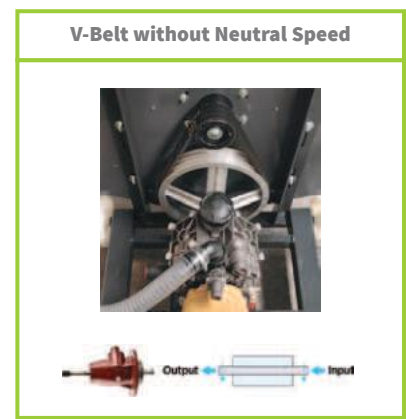
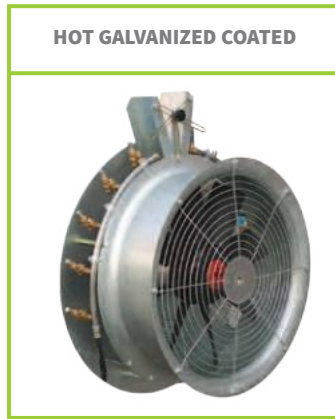

HBA Type

- 60 cm (24" – 8 nozzles)
- 75 cm (28" – 10 nozzles)
- Painted
- Hot Galvanized Coated

- Single Propeller
- V-Belt with Neutral Speed

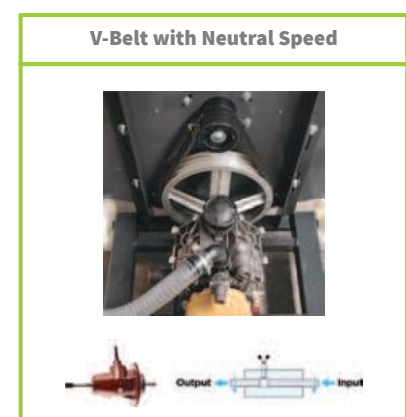

NOZZLE

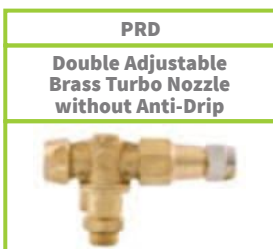



TANK

- Polyethylene Tank with Hand Wash
- Capacities : 400 LT - 500 LT - 600 LT - 800 LT - 1000 LT - 1200 LT

PUMP

A-105 Pump



PRESSURE	50 BAR
MEMBRANE	4 PISTON
FLOW RATE	105 LT/MIN

CONTROL UNIT (REGULATOR)

VDR-50
Regulator 2 Way



Bymatic



Braglia M200
Pressure Manual



Braglia E200
Pressure Electric



FAN GROUP

HBA Type

- 75 cm (28” – 10 nozzles)
- 85 cm (32” – 12 nozzles)
- *Painted*
- *Hot Galvanized Coated*
- *Inox Hood + Painted Back Plate*
- *Inox Hood + Galvanized Back Plate*
- *Single Propeller*
- *V-Belt with Neutral Speed*

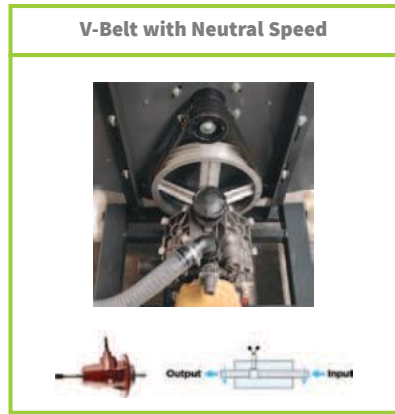
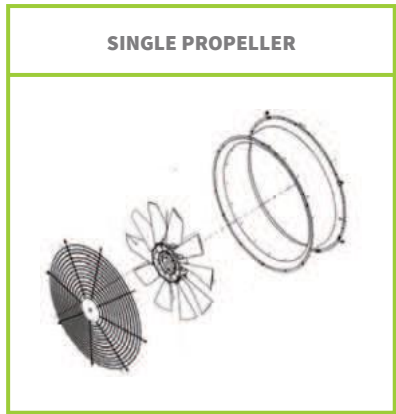

NOZZLE





TANK

- Polyethylene Tank with Hand Wash + Clean Water Tank
- Capacities : 400 LT - 500 LT - 600 LT - 800 LT - 1000 LT - 1200 LT

PUMP

A-105 Pump



PRESSURE	50 BAR
MEMBRANE	4 PISTON
FLOW RATE	105 LT/MIN

CONTROL UNIT (REGULATOR)

VDR-50
Regulator 2 Way



Bymatic



FAN GROUP

HBA Type

- 75 cm (28" – 10 nozzles)
- 85 cm (32" – 12 nozzles)
- Painted
- Hot Galvanized Coated
- Inox Hood + Painted Back Plate
- Inox Hood + Galvanized Back Plate
- Single Propeller
- Single Propeller + Counter Fan
- V-Belt with Neutral Speed

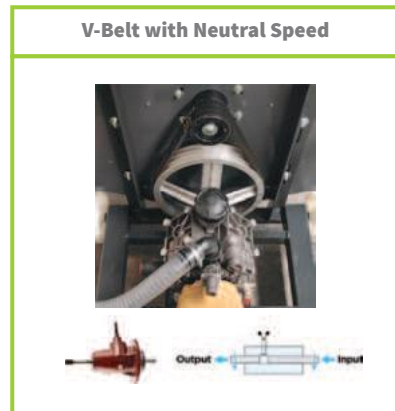
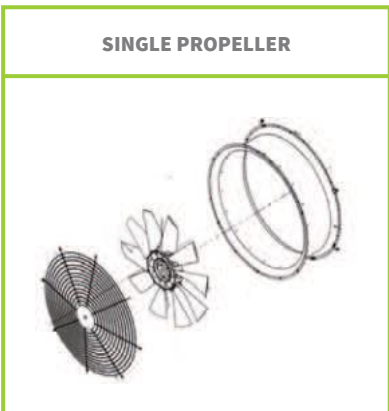
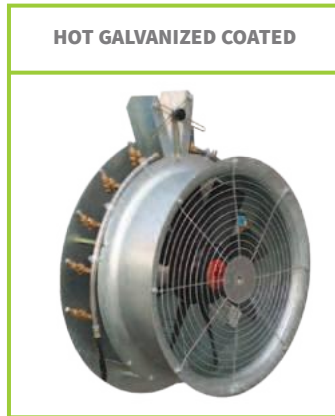

OPTIONAL



NOZZLE





TANK

- Polyethylene Tank with Hand Wash + Clean Water Tank
- Capacities : 600 LT – 800 LT – 1000 LT – 1200 LT

PUMP

A-105 Pump



PRESSURE	50 BAR
MEMBRANE	4 PISTON
FLOW RATE	105 LT/MIN

IDM-140 Pump



PRESSURE	50 BAR
MEMBRANE	3 PISTON
FLOW RATE	137 LT/MIN

Comet APS-121S



PRESSURE	50 BAR
MEMBRANE	3 PISTON
FLOW RATE	115 LT/MIN

Comet APS-145



PRESSURE	50 BAR
MEMBRANE	4 PISTON
FLOW RATE	142 LT/MIN

CONTROL UNIT (REGULATOR)

VDR-50
Regulator 2 Way



Bymatic



Braglia M200
Pressure Manual



Braglia E200
Pressure Electric



FAN GROUP

HBG Type

- 75 cm (28" – 12 nozzles)
- 85 cm (32" – 14 Nozzles)
- 90 cm (36" – 16 Nozzles)
- Hot Galvanized Coated
- Inox Hood + Painted Back Plate
- Inox Hood + Galvanized Back Plate
- Single Propeller
- Single Propeller + Counter Fan
- 2 Speed Gearbox

HOT GALVANIZED COATED



INOX HOOD + PAINTED BACK PLATE



INOX HOOD + GALVANIZED BACK PLATE



SINGLE PROPELLER

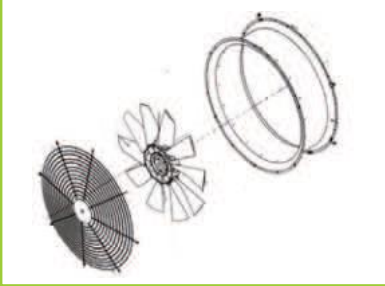

SINGLE PROPELLER + COUNTER FAN

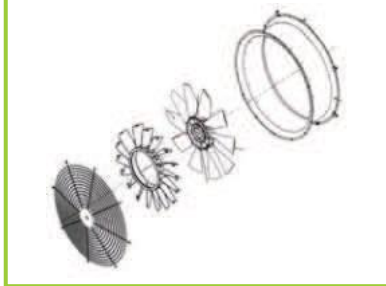

OPTIONAL

WN75

Wings for 75 cm



WN90

Wings for 85 cm and 90 cm



NOZZLE

PRS

Double Adjustable Brass Turbo Nozzle with Anti-Drip





TANK

- Polyethylene Tank with Hand Wash + Clean Water Tank
- Capacities : 400 LT – 500 LT – 600 LT – 800 LT – 1000 LT – 1200 LT

PUMP

A-105 Pump	
	
PRESSURE	50 BAR
MEMBRANE	4 PISTON
FLOW RATE	105 LT/MIN

CONTROL UNIT (REGULATOR)

VDR-50 Regulator 2 Way

Bymatic

Braglia M200 Pressure Manual

Braglia E200 Pressure Electric

NOZZLE

PRS
Double Adjustable Brass Turbo Nozzle with Anti-Drip

FAN GROUP

VSA Type

- 75 cm (28" – 12 nozzles)
- Hot Galvanized Coated
- Inox Hood + Painted Back Plate
- Inox Hood + Galvanized Back Plate
- Single Propeller
- Single Propeller + Counter Fan
- V-Belt with Neutral Speed

HOT GALVANIZED COATED



INOX HOOD + PAINTED BACK PLATE



INOX HOOD + GALVANIZED BACK PLATE



WSA Type

- 75 cm (28" – 10 nozzles)
- Hot Galvanized Coated
- Inox Hood + Painted Back Plate
- Inox Hood + Galvanized Back Plate
- Single Propeller
- Single Propeller + Counter Fan
- V-Belt with Neutral Speed

HOT GALVANIZED COATED



INOX HOOD + PAINTED BACK PLATE



INOX HOOD + GALVANIZED BACK PLATE



SINGLE PROPELLER

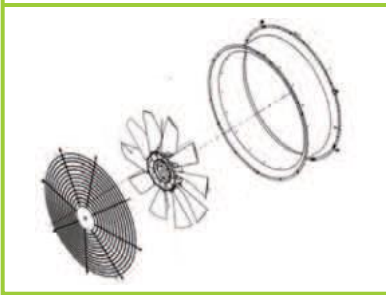

SINGLE PROPELLER + COUNTER FAN

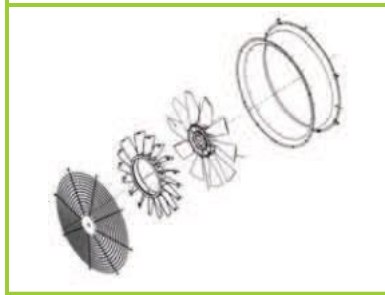

V-Belt with Neutral Speed





TANK

- Polyethylene Tank with Hand Wash + Clean Water Tank
- Capacities : 400 LT – 500 LT – 600 LT – 800 LT – 1000 LT – 1200 LT

PUMP

A-105 Pump



PRESSURE	50 BAR
MEMBRANE	4 PISTON
FLOW RATE	105 LT/MIN

IDM-140 Pump



PRESSURE	50 BAR
MEMBRANE	3 PISTON
FLOW RATE	137 LT/MIN

Comet APS-121S



PRESSURE	50 BAR
MEMBRANE	3 PISTON
FLOW RATE	115 LT/MIN

Comet APS-145



PRESSURE	50 BAR
MEMBRANE	4 PISTON
FLOW RATE	142 LT/MIN

CONTROL UNIT (REGULATOR)

**VDR-50
Regulator 2 Way**



Bymatic



**Braglia M200
Pressure Manual**



**Braglia E200
Pressure Electric**



NOZZLE

PRS
Double Adjustable
Brass Turbo Nozzle
with Anti-Drip



FAN GROUP

VSG Type

- 75 cm (28" – 12 nozzles)
- Hot Galvanized Coated
- Inox Hood + Painted Back Plate
- Inox Hood + Galvanized Back Plate
- Single Propeller
- Single Propeller + Counter Fan
- 2 Speed Gearbox



WSG Type

- 75 cm (28" – 10 nozzles)
- 85 cm (32" – 12 nozzles)
- Hot Galvanized Coated
- Inox Hood + Painted Back Plate
- Inox Hood + Galvanized Back Plate
- Single Propeller
- Single Propeller + Counter Fan
- 2 Speed Gearbox



WWG Type

- 90 cm (32" – 16 nozzles)
- Hot Galvanized Coated
- Inox Hood + Painted Back Plate
- Inox Hood + Galvanized Back Plate
- Single Propeller + Counter Fan
- Double Propeller
- 2 Speed Gearbox

HOT GALVANIZED COATED



INOX HOOD + PAINTED BACK PLATE



INOX HOOD + GALVANIZED BACK PLATE



SINGLE PROPELLER

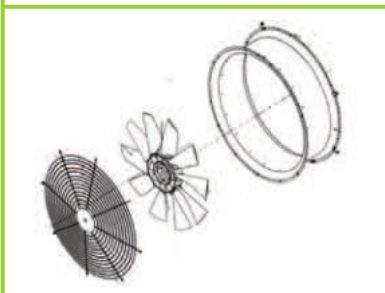

SINGLE PROPELLER + COUNTER FAN





TANK

- Polyethylene Tank with Hand Wash + Clean Water Tank
- Capacities : 600 LT – 800 LT – 1000 LT – 1200 LT

PUMP

A-105 Pump



PRESSURE	50 BAR
MEMBRANE	4 PISTON
FLOW RATE	105 LT/MIN

IDM-140 Pump



PRESSURE	50 BAR
MEMBRANE	3 PISTON
FLOW RATE	137 LT/MIN

IDM-200 Pump



PRESSURE	50 BAR
MEMBRANE	4 PISTON
FLOW RATE	180 LT/MIN

Comet APS-121S



PRESSURE	50 BAR
MEMBRANE	3 PISTON
FLOW RATE	115 LT/MIN

Comet APS-145



PRESSURE	50 BAR
MEMBRANE	4 PISTON
FLOW RATE	142 LT/MIN

CONTROL UNIT (REGULATOR)

VDR-50
Regulator 2 Way



Bymatic



FAN GROUP

Cannon Head

- Painted
- Hot Galvanized Coated
- 2 Speed Gearbox

PAINTED



HOT GALVANIZED COATED



NOZZLE

Double Adjustable
Brass Turbo Nozzle
with Anti-Drip





TANK

- Polyethylene Tank with Hand Wash + Clean Water Tank
- Capacities : 600 LT - 800 LT - 1000 LT - 1200 LT

PUMP

A-105 Pump



PRESSURE	50 BAR
MEMBRANE	4 PISTON
FLOW RATE	105 LT/MIN

IDM-140 Pump



PRESSURE	50 BAR
MEMBRANE	3 PISTON
FLOW RATE	137 LT/MIN

IDM-200 Pump



PRESSURE	50 BAR
MEMBRANE	4 PISTON
FLOW RATE	180 LT/MIN

Comet APS-121S



PRESSURE	50 BAR
MEMBRANE	3 PISTON
FLOW RATE	115 LT/MIN

Comet APS-145



PRESSURE	50 BAR
MEMBRANE	4 PISTON
FLOW RATE	142 LT/MIN

CONTROL UNIT (REGULATOR)

VDR-50
Regulator 2 Way



Bymatic



FAN GROUP

Robot Head

- Painted
- Hot Galvanized Coated
- 2 Speed Gearbox

PAINTED



HOT GALVANIZED COATED



NOZZLE

Double Adjustable
Brass Turbo Nozzle
with Anti-Drip





TANK

- Polyethylene Tank with Hand Wash + Clean Water Tank
- Capacities : 1000 LT – 1600 LT -2000 LT – 3000 LT

DRAWBAR



TIRE

- 10.0/80-12 for 1000 LT - 10.0/75-15.3 for 1600 LT and 2000 LT
- 11.5/80-15.3 for 3000 LT

PUMP

A-105 Pump



PRESSURE	50 BAR
MEMBRANE	4 PISTON
FLOW RATE	105 LT/MIN

IDM-140 Pump



PRESSURE	50 BAR
MEMBRANE	3 PISTON
FLOW RATE	137 LT/MIN

IDM-200 Pump



PRESSURE	50 BAR
MEMBRANE	4 PISTON
FLOW RATE	180 LT/MIN

Comet APS-96



PRESSURE	50 BAR
MEMBRANE	4 PISTON
FLOW RATE	88 LT/MIN

Comet APS-121S



PRESSURE	50 BAR
MEMBRANE	3 PISTON
FLOW RATE	115 LT/MIN

Comet APS-145



PRESSURE	50 BAR
MEMBRANE	4 PISTON
FLOW RATE	142 LT/MIN

CONTROL UNIT (REGULATOR)

**VDR-50
Regulator 2 Way**



Bymatic



NOZZLE

PRS

**Double Adjustable
Brass Turbo Nozzle
with Anti-Drip**



FAN GROUP

HBG Type

- 75 cm (28" – 12 nozzles)
- 85 cm (32" – 14 Nozzles)
- 90 cm (36" – 16 Nozzles)
- Hot Galvanized Coated
- Inox Hood + Painted Back Plate
- Inox Hood + Galvanized Back Plate
- Single Propeller
- Single Propeller + Counter Fan
- Double Propeller
- 2 Speed Gearbox

HOT GALVANIZED COATED



INOX HOOD + PAINTED BACK PLATE



INOX HOOD + GALVANIZED BACK PLATE



HBY Type

- 90 cm (36" – 16 Nozzles)
- Hot Galvanized Coated
- Single Propeller + Counter Fan
- Double Propeller
- 2 Speed Gearbox

HOT GALVANIZED COATED



SINGLE PROPELLER

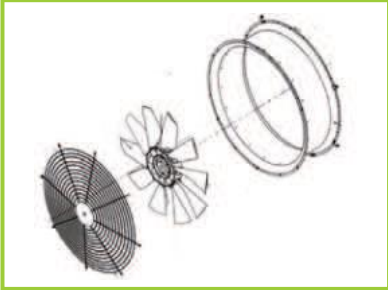

SINGLE PROPELLER + COUNTER FAN

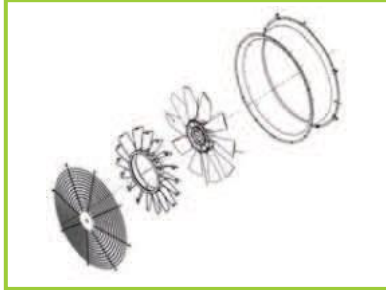

DOUBLE PROPELLER

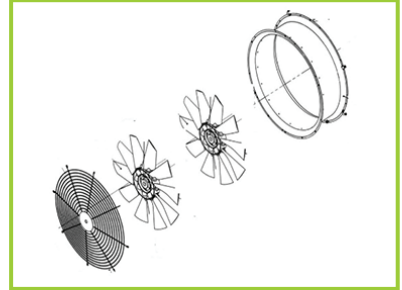

OPTIONAL

WN75

Wings for 75 cm



WN90

Wings for 85 cm and 90 cm



OPTIONAL

**Powder Mixer in
Basket Filter**



**Can Wash in
Basket Filter**





TANK

- Polyethylene Tank with Hand Wash + Clean Water Tank
- Capacities : 2000 LT – 3000 LT – 4000 LT

DRAWBAR

TDW

Straight Drawbar



SDW

Steering Drawbar



TIRE

- 10.0/75-15.3 for 2000 LT / 11.5/80-15.3 for 3000 LT
- 12.5/80-15.3 for 4000 LT

PUMP

IDM-140 Pump



PRESSURE	50 BAR
MEMBRANE	3 PISTON
FLOW RATE	137 LT/MIN

IDM-200 Pump



PRESSURE	50 BAR
MEMBRANE	4 PISTON
FLOW RATE	180 LT/MIN

Comet APS-145



PRESSURE	50 BAR
MEMBRANE	4 PISTON
FLOW RATE	142 LT/MIN

Comet IDS-2001



PRESSURE	50 BAR
MEMBRANE	4 PISTON
FLOW RATE	185 LT/MIN

CONTROL UNIT (REGULATOR)

Bymatic



Braglia M200
Pressure Manual



Braglia E200
Pressure Electric



Sensor with Braglia
M200/E200



NOZZLE

PRS

Double Adjustable
Brass Turbo Nozzle
with Anti-Drip



FAN GROUP

HBG Type

- 90 cm (36" – 16 Nozzles)
- Hot Galvanized Coated
- Inox Hood + Painted Back Plate
- Inox Hood + Galvanized Back Plate
- Single Propeller + Counter Fan
- Double Propeller
- 2 Speed Gearbox

HOT GALVANIZED COATED



INOX HOOD + PAINTED BACK PLATE



INOX HOOD + GALVANIZED BACK PLATE



HBY Type

- 90 cm (36" – 16 Nozzles)
- Hot Galvanized Coated
- Single Propeller + Counter Fan
- Double Propeller
- 2 Speed Gearbox

HOT GALVANIZED COATED



SINGLE PROPELLER + COUNTER FAN



DOUBLE PROPELLER

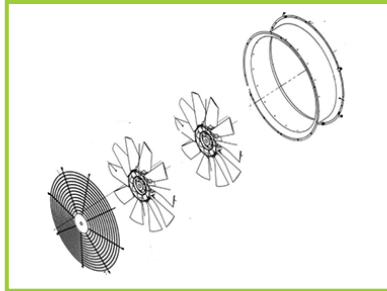

OPTIONAL

WN75

Wings for 75 cm



WN90

Wings for 85 cm and 90 cm



OPTIONAL

**Powder Mixer in
Basket Filter**



**Can Wash in
Basket Filter**





TANK

- Polyethylene Tank with Hand Wash + Clean Water Tank
- Capacities : 1000 LT - 1600 LT - 2000 LT - 3000 LT

TIRE

- 10.0/80-12 for 1000 LT - 10.0/75-15.3 for 1600 LT and 2000 LT
- 11.5/80-15.3 for 3000 LT

DRAWBAR



NOZZLE



PUMP

A-105 Pump



PRESSURE	50 BAR
MEMBRANE	4 PISTON
FLOW RATE	105 LT/MIN

IDM-140 Pump



PRESSURE	50 BAR
MEMBRANE	3 PISTON
FLOW RATE	137 LT/MIN

IDM-200 Pump



PRESSURE	50 BAR
MEMBRANE	4 PISTON
FLOW RATE	180 LT/MIN

Comet APS-96



PRESSURE	50 BAR
MEMBRANE	4 PISTON
FLOW RATE	88 LT/MIN

Comet APS-121S



PRESSURE	50 BAR
MEMBRANE	3 PISTON
FLOW RATE	115 LT/MIN

Comet APS-145



PRESSURE	50 BAR
MEMBRANE	4 PISTON
FLOW RATE	142 LT/MIN

CONTROL UNIT (REGULATOR)

**VDR-50
Regulator 2 Way**



Bymatic



FAN GROUP

SINGLE PROPELLER

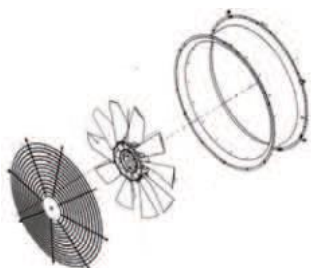

SINGLE PROPELLER + COUNTER FAN



DOUBLE PROPELLER

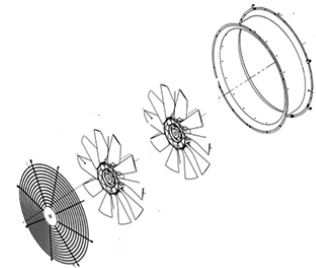

FAN GROUP

VLG Type

- 75 cm (28" – 10 nozzles)
L = 150 cm
 - 85 cm (32" – 14 Nozzles)
L = 170 cm
 - 90 cm (36" – 18 Nozzles)
L = 190 cm / L = 235 cm
- Hot Galvanized Coated
 - Inox Hood + Painted Back Plate
 - Inox Hood + Galvanized Back Plate
- Single Propeller
 - Single Propeller + Counter Fan
 - Double Propeller
- 2 Speed Gearbox

HOT GALVANIZED COATED



INOX HOOD + PAINTED BACK PLATE



INOX HOOD + GALVANIZED BACK PLATE



WSG Type

- 75 cm (28" – 10 nozzles)
L = 150 cm
 - 85 cm (32" – 12 Nozzles)
L = 160 cm
- Hot Galvanized Coated
 - Inox Hood + Painted Back Plate
 - Inox Hood + Galvanized Back Plate
- Single Propeller
 - Single Propeller + Counter Fan
 - Double Propeller
- 2 Speed Gearbox

HOT GALVANIZED COATED



INOX HOOD + PAINTED BACK PLATE



INOX HOOD + GALVANIZED BACK PLATE



WLG Type

- 85 cm (32") – 14 Nozzles)
L = 170 cm
- 90 cm (36") – 16 Nozzles)
L = 190 cm

- Hot Galvanized Coated
- Inox Hood + Painted Back Plate
- Inox Hood + Galvanized Back Plate

- Single Propeller
- Single Propeller + Counter Fan
- Double Propeller
- 2 Speed Gearbox

HOT GALVANIZED COATED



INOX HOOD + PAINTED BACK PLATE



INOX HOOD + GALVANIZED BACK PLATE



WWG Type

- 90 cm (36") – 16 Nozzles)
L = 190 cm / L = 235 cm

- Hot Galvanized Coated
- Inox Hood + Painted Back Plate
- Inox Hood + Galvanized Back Plate

- Single Propeller + Counter Fan
- 2 Speed Gearbox

HOT GALVANIZED COATED



INOX HOOD + PAINTED BACK PLATE



INOX HOOD + GALVANIZED BACK PLATE



OPTIONAL

Powder Mixer in Basket Filter



Can Wash in Basket Filter





TANK

- Polyethylene Tank with Hand Wash + Clean Water Tank
- Capacities : 600 LT - 1000 LT - 1200 LT - 1600 LT - 2000 LT

TIRE

- 6.00-16 for 600 LT - 10.0/80-12 for 1000 LT
- 10.0/75-15.3 for 1600 LT and 2000 LT

DRAWBAR



PUMP

A-105 Pump



PRESSURE	50 BAR
MEMBRANE	4 PISTON
FLOW RATE	105 LT/MIN

IDM-140 Pump



PRESSURE	50 BAR
MEMBRANE	3 PISTON
FLOW RATE	137 LT/MIN

IDM-200 Pump



PRESSURE	50 BAR
MEMBRANE	4 PISTON
FLOW RATE	180 LT/MIN

Comet APS-96



PRESSURE	50 BAR
MEMBRANE	4 PISTON
FLOW RATE	88 LT/MIN

Comet APS-121S



PRESSURE	50 BAR
MEMBRANE	3 PISTON
FLOW RATE	115 LT/MIN

Comet APS-145



PRESSURE	50 BAR
MEMBRANE	4 PISTON
FLOW RATE	142 LT/MIN

CONTROL UNIT (REGULATOR)

**VDR-50
Regulator 2 Way**



Bymatic



**Braglia M200
Pressure Manual**



**Braglia E200
Pressure Electric**



**Sensor with Braglia
M200/E200**



NOZZLE

**PRS
Double Adjustable
Brass Turbo Nozzle
with Anti-Drip**



FAN GROUP

RVL Type

- 90 cm (36" – 18 Nozzles)
- L = 190 cm
- *Inox Hood + Galvanized Back Plate*
- *Single Propeller + Counter Fan*
- *2 Speed Big Gearbox*

INOX HOOD + GALVANIZED BACK
PLATE



RTL Type

- 85 cm (32" – 18 Nozzles)
- L = 180 cm
- *Inox Hood + Galvanized Back Plate*
- *Single Propeller + Counter Fan*
- *2 Speed Big Gearbox*

INOX HOOD + GALVANIZED BACK
PLATE



SINGLE PROPELLER + COUNTER FAN

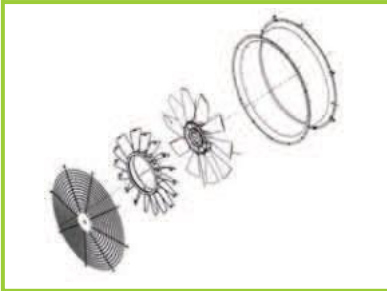

OPTIONAL

Powder Mixer in Basket Filter



Can Wash in Basket Filter





TANK

- Polyethylene Tank with Hand Wash + Clean Water Tank
- Capacities : 600 LT - 1000 LT – 1600 LT -2000 LT

TIRE

- 6.00-16 for 600 LT - 10.0/80-12 for 1000 LT
- 10.0/75-15.3 for 1600 LT and 2000 LT

DRAWBAR



OPTIONAL



PUMP

IDM-140 Pump



PRESSURE	50 BAR
MEMBRANE	3 PISTON
FLOW RATE	137 LT/MIN

IDM-200 Pump



PRESSURE	50 BAR
MEMBRANE	4 PISTON
FLOW RATE	180 LT/MIN

Comet APS-121S



PRESSURE	50 BAR
MEMBRANE	3 PISTON
FLOW RATE	115 LT/MIN

Comet APS-145



PRESSURE	50 BAR
MEMBRANE	4 PISTON
FLOW RATE	142 LT/MIN

CONTROL UNIT (REGULATOR)

Bymatic



NOZZLE

PRS

Double Adjustable Brass Turbo Nozzle with Anti-Drip



FAN GROUP

Cannon Head

- Painted
- Hot Galvanized Coated

• 2 Speed Gearbox

PAINTED



HOT GALVANIZED COATED





TANK

- Polyethylene Tank with Hand Wash + Clean Water Tank
- Capacities : 2000 LT - 3000 LT - 4000 LT

TIRE

- 10.0/75-15.3 for 2000 LT / 11.5/80-15.3 for 3000 LT
- 12.5/80-15.3 for 4000 LT

DRAWBAR



PUMP

IDM-140 Pump



PRESSURE	50 BAR
MEMBRANE	3 PISTON
FLOW RATE	137 LT/MIN

IDM-200 Pump



PRESSURE	50 BAR
MEMBRANE	4 PISTON
FLOW RATE	180 LT/MIN

Comet APS-145



PRESSURE	50 BAR
MEMBRANE	4 PISTON
FLOW RATE	142 LT/MIN

Comet IDS-2001



PRESSURE	50 BAR
MEMBRANE	4 PISTON
FLOW RATE	185 LT/MIN

CONTROL UNIT (REGULATOR)

Bymatic



NOZZLE

PRS

Double Adjustable Brass Turbo Nozzle with Anti-Drip



FAN GROUP

Robot Head

- Painted
- Hot Galvanized Coated

- 2 Speed Gearbox

PAINTED



HOT GALVANIZED COATED



OPTIONAL

Powder Mixer in Basket Filter



Can Wash in Basket Filter



The image features a dense background of green trees and foliage. A dark blue horizontal band is overlaid across the middle, containing the Arigo logo and brand name. The logo is a white stylized 'A' inside a white semi-circular shape. To the right of the logo, the word 'ARIGO' is written in a bold, white, sans-serif font. In the lower right corner, the lower leg and foot of a person wearing dark pants and a shoe are visible, standing on a dirt path. A green hose or pipe lies on the ground near the person's foot.

ARIGO



GARDEN SPRAYER



TANK

- Polyethylene Tank with Hand Wash
- Capacities : 200 LT - 300 LT - 400 LT - 500 LT - 600 LT - 800 LT - 1000 LT

CHASSIS

- Tubular for 200 LT - 300 LT - 400 LT - 500 LT - 600 LT
- Profile Extended for 400 LT - 500 LT - 600 LT - 800 LT - 1000 LT

PUMP

E-30 Pump



PRESSURE	30 BAR
MEMBRANE	3 PISTON
FLOW RATE	30 LT/MIN

B-71 Pump



PRESSURE	40 BAR
MEMBRANE	3 PISTON
FLOW RATE	70 LT/MIN

B-80 Pump



PRESSURE	40 BAR
MEMBRANE	3 PISTON
FLOW RATE	80 LT/MIN

A-105 Pump



PRESSURE	50 BAR
MEMBRANE	4 PISTON
FLOW RATE	105 LT/MIN

CONTROL UNIT (REGULATOR)

C-50 Regulator 2 Way



VDR-50 Regulator 2 Way



ACCESSORIES

Hose Reel



Double Hose Reel



Short Spray Gun



Long Spray Gun



Trigger Spray Gun



Turbo Spray Gun



10 mm 90 bar Hose (10 mt -15 mt - 25 mt - 50 mt - 75 mt - 100 mt)





TANK

- Polyethylene Tank with Hand Wash
- Capacities : 200 LT - 300 LT - 400 LT - 500 LT - 600 LT - 800 LT - 1000 LT - 1200 LT

CHASSIS

- Profile Extended

PUMP

E-30 Pump



PRESSURE	30 BAR
MEMBRANE	3 PISTON
FLOW RATE	30 LT/MIN

B-80 Pump



PRESSURE	40 BAR
MEMBRANE	3 PISTON
FLOW RATE	80 LT/MIN

A-105 Pump



PRESSURE	50 BAR
MEMBRANE	4 PISTON
FLOW RATE	105 LT/MIN

CONTROL UNIT (REGULATOR)

**C-50
Regulator 2 Way**



**VDR-50
Regulator 2 Way**



ACCESSORIES

Hose Reel



**Double
Hose Reel**



**Short
Spray Gun**



**Long
Spray Gun**



**Trigger
Spray Gun**



**Turbo
Spray Gun**



**10 mm 90 bar Hose
(10 mt -15 mt - 25 mt - 50 mt -
75 mt - 100 mt)**





TANK

- Polyethylene Tank with Hand Wash + Clean Water Tank
- Capacities : 200 LT - 300 LT - 400 LT - 500 LT - 600 LT - 800 LT - 1000 LT - 1200 LT

CHASSIS

- Profile Extended

PUMP

E-30 Pump



PRESSURE	30 BAR
MEMBRANE	3 PISTON
FLOW RATE	30 LT/MIN

B-80 Pump



PRESSURE	40 BAR
MEMBRANE	3 PISTON
FLOW RATE	80 LT/MIN

A-105 Pump



PRESSURE	50 BAR
MEMBRANE	4 PISTON
FLOW RATE	105 LT/MIN

CONTROL UNIT (REGULATOR)

**C-50
Regulator 2 Way**



**VDR-50
Regulator 2 Way**



ACCESSORIES

Hose Reel



**Double
Hose Reel**



**Short
Spray Gun**



**Long
Spray Gun**



**Trigger
Spray Gun**



**Turbo
Spray Gun**



**10 mm 90 bar Hose
(10 mt -15 mt - 25 mt - 50 mt -
75 mt - 100 mt)**





TANK

- Polyethylene Tank with Hand Wash
- Capacities : 1000 LT - 1600 LT - 2000 LT - 3000 LT

DRAWBAR

BDW

Straight Drawbar



TIRE

- 10.0/80-12 for 1000 LT - 10.0/75-15.3 for 1600 LT and 2000 LT
- 11.5/80-15.3 for 3000 LT

PUMP

A-105 Pump



PRESSURE	50 BAR
MEMBRANE	4 PISTON
FLOW RATE	105 LT/MIN

IDM-140 Pump



PRESSURE	50 BAR
MEMBRANE	3 PISTON
FLOW RATE	137 LT/MIN

VDR-50
Regulator 2 Way



CONTROL UNIT (REGULATOR)

ACCESSORIES

Hose Reel



Double
Hose Reel



Short
Spray Gun



Long
Spray Gun



Trigger
Spray Gun

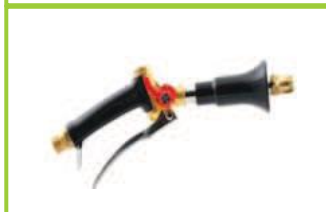

Turbo
Spray Gun



10 mm 90 bar Hose
(10 mt -15 mt - 25 mt - 50 mt -
75 mt - 100 mt)



TRACTOR REAR ATTACHMENTS





 **ARIGO**

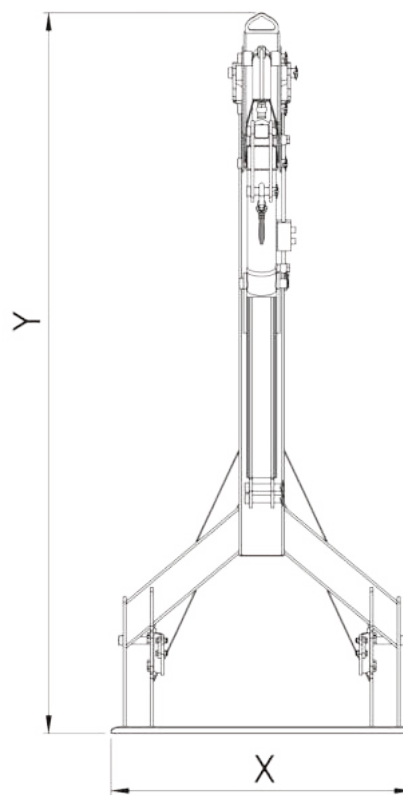
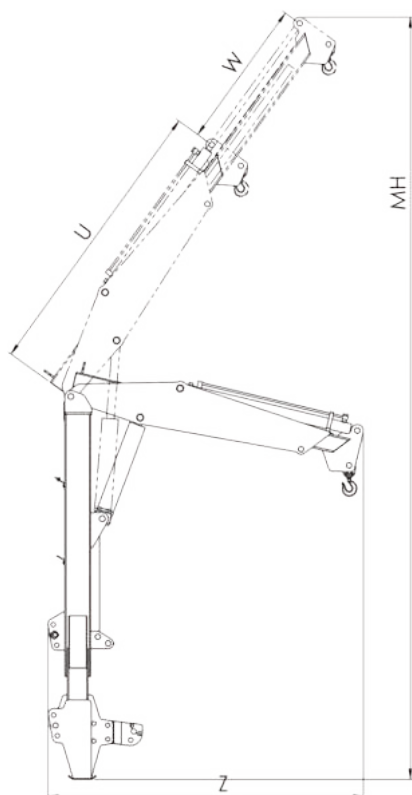

Overall Width (X)	1,00 m
Overall Height (Y)	2,39 m
Overall Depth (Z)	1,81 m
U	1,65 m
W	0,86 m
Max. Height (MH)	4,37 m
Unladen Weight	250 kg
Working Pressure	160 bar

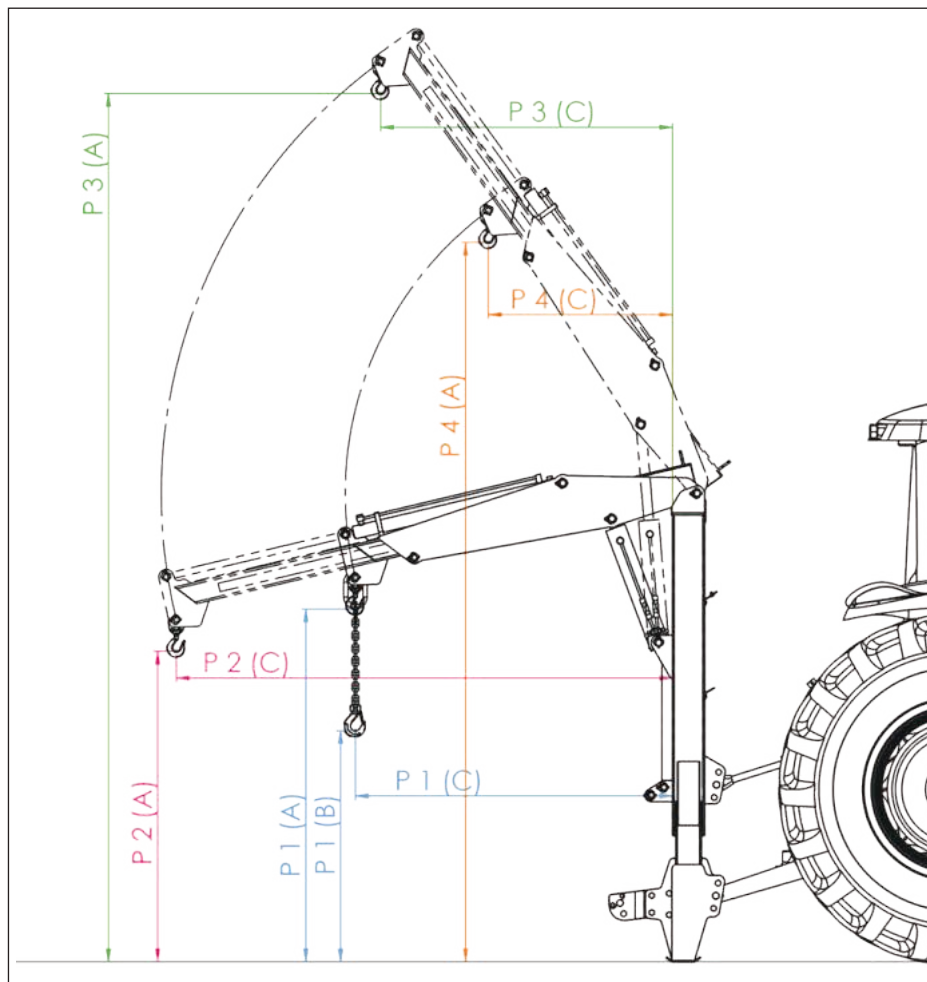

POSITION	A (with hook)	B (with chain)	C	MAXIMUM LIFTING CAPACITY
P 1	1,65 m	1,08 m	1,48 m	1000kg
P 2	1,45 m	0,88 m	2,32 m	600kg
P 3	4,06 m	3,49 m	1,36 m	600kg
P 4	3,37 m	2,80 m	0,86 m	1000kg

OPTIONAL

Big Bag Attachment



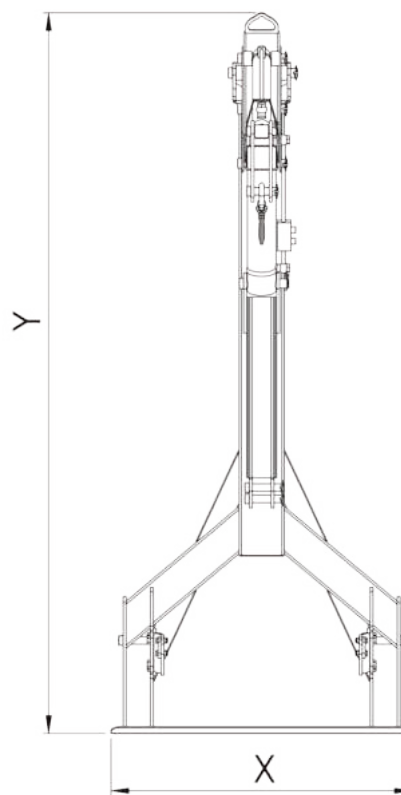
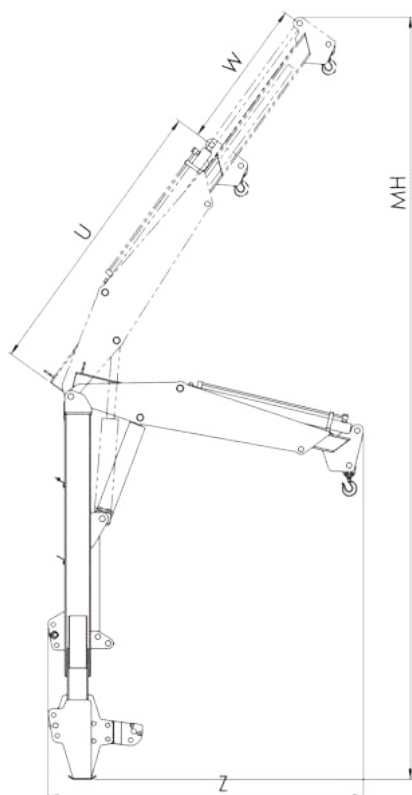

Overall Width (X)	1,00 m
Overall Height (Y)	2,39 m
Overall Depth (Z)	1,90 m
U	1,70 m
W	0,86 m
Max. Height (MH)	4,69 m
Unladen Weight	266 kg
Working Pressure	160 bar

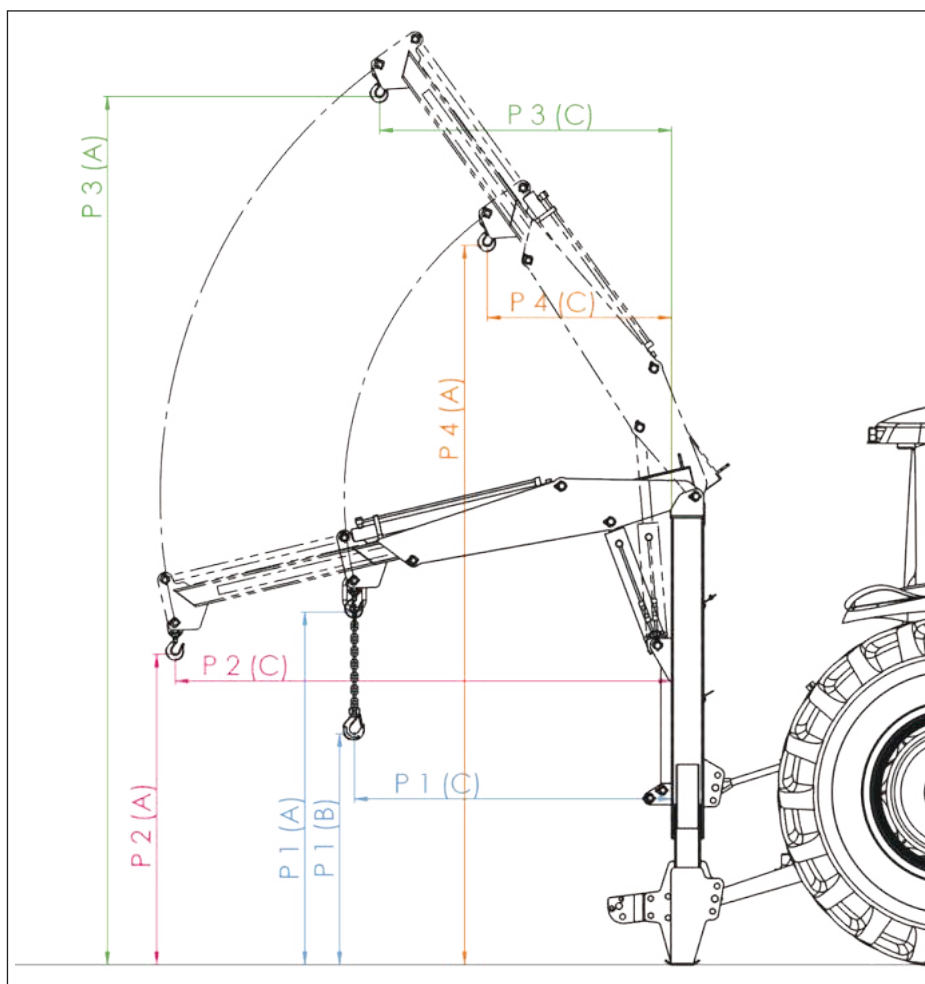

POSITION	A (with hook)	B (with chain)	C	MAXIMUM LIFTING CAPACITY
P 1	1,61 m	1,04 m	1,61 m	1500kg
P 2	1,41 m	0,84 m	2,45 m	1000kg
P 3	4,51 m	3,94 m	0,83 m	1000kg
P 4	3,70 m	3,13 m	0,53 m	1500kg

OPTIONAL



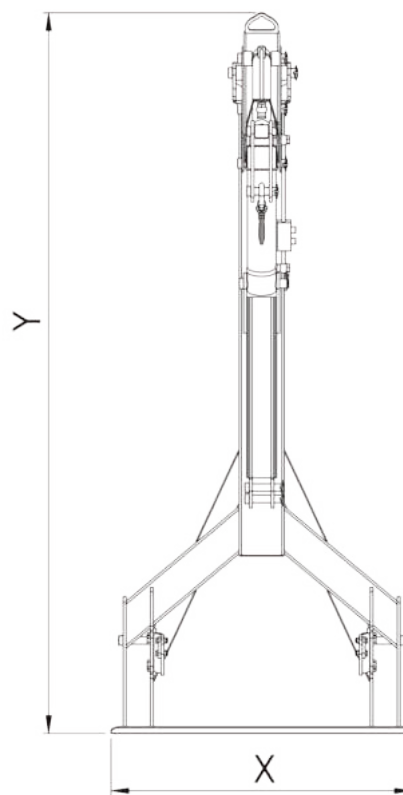
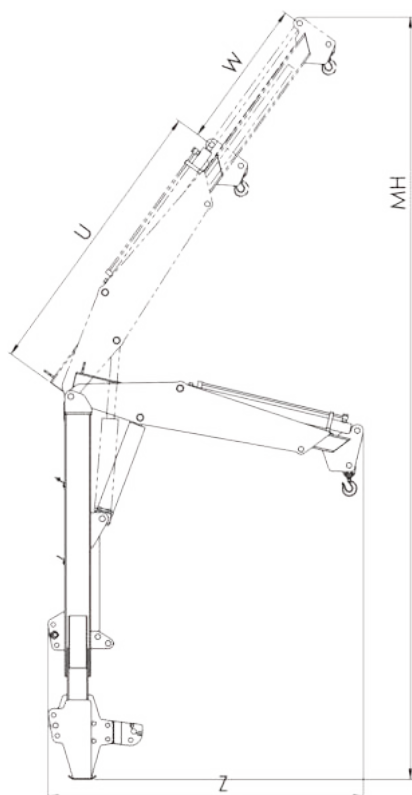

Overall Width (X)	1,00 m
Overall Height (Y)	2,46 m
Overall Depth (Z)	2,48 m
U	2,27 m
W	1,23 m
Max. Height (MH)	5,66 m
Unladen Weight	330 kg
Working Pressure	160 bar

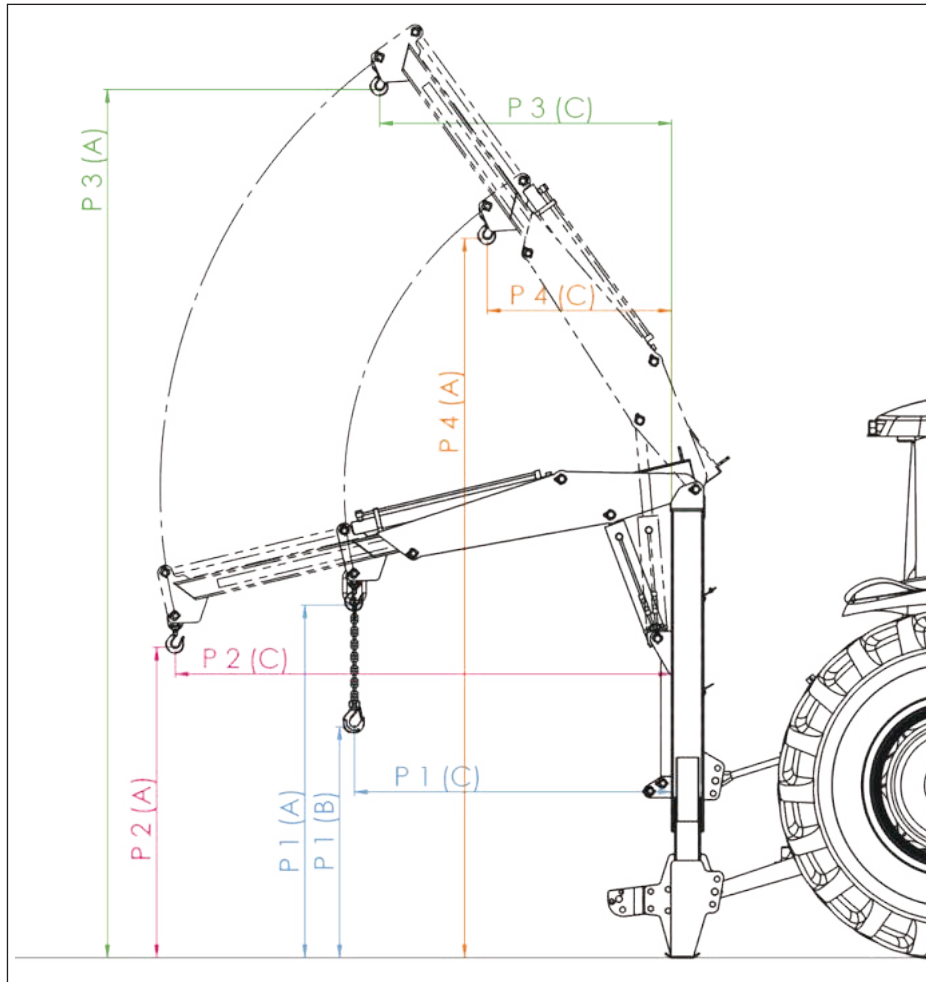

POSITION	A (with hook)	B (with chain)	C	MAXIMUM LIFTING CAPACITY
P 1	1,38 m	0,81 m	2,19 m	1750 kg
P 2	1,05 m	0,48 m	3,37 m	1250 kg
P 3	5,47 m	4,90 m	1,06 m	1250 kg
P 4	4,30 m	3,73 m	0,67 m	1750 kg

OPTIONAL





BLY-M

BLY SERIES
BIG BAG LIFTER





Lacivert Sanayi Sitesi Fevzi Çakmak Mh.
10762 Sokak 3AR, 42050 Karatay/KONYA/TÜRKİYE

www.arigo.com.tr - info@arigo.com.tr

+90 332 503 64 21